

C-FL6

Forged Floating Ball Valves

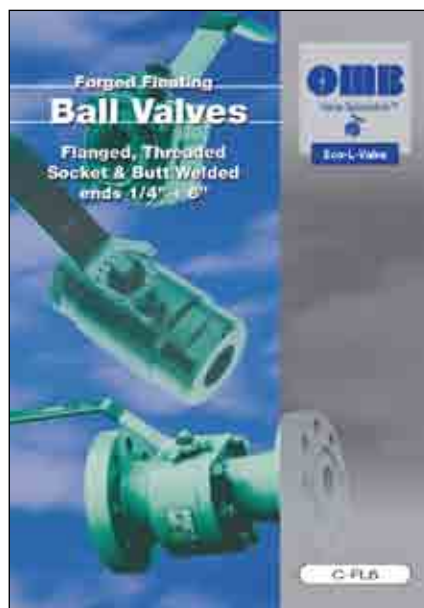

OMB is a family owned and managed business founded by Mr. Roberto Brevi in 1973. His goal was to build a company that would specialize in the manufacturing of forged steel valves. Since its founding, OMB's capabilities have grown to cover small diameter gate/globe/check valves, small and large diameter floaters and trunnion mounted ball valves, through conduit gate valves, and triple offset butterfly valves. Today OMB operates 5 plants in 3 countries with a worldwide network of agents, distributors, and sales offices.

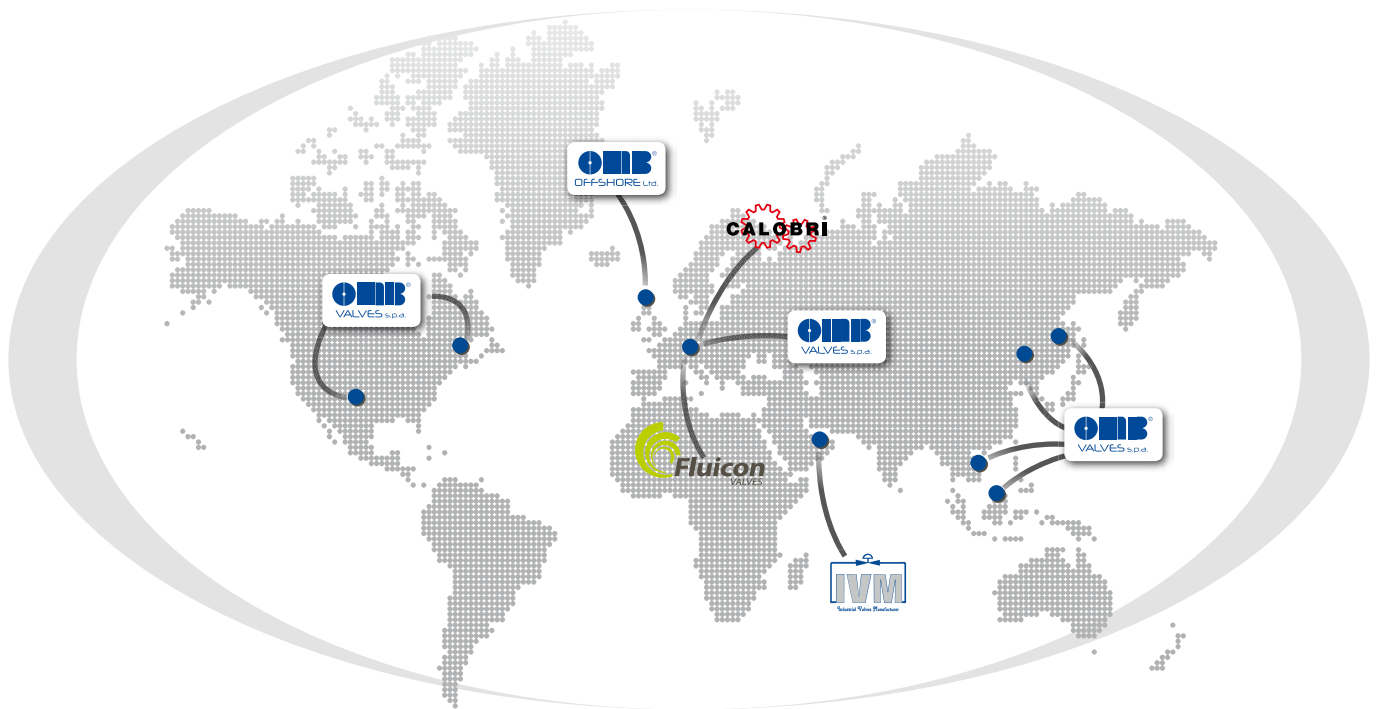

NEW in this version

This is the 6th edition of floating ball valves catalogue. In this version we made a general revision of dimensional tables and re-organized sections into different valve types.

C-FL5 the previous version

The content of this catalog is copyrighted by OMB Valves S.p.A. (c) 2009. Nothing included in this catalog can be reproduced in any form without obtaining prior written consent by OMB Valves S.p.A. All photos and images published are copyrighted; the use of images, even if digitally modified to take away the OMB logo will be prosecuted to the maximum extent of the law.



The Group

At OMB we have developed a comprehensive range of engineered valve products installed globally across a wide range of industries:

- Offshore
- Subsea
- Refining
- Petrochemical
- Chemical
- Desalination

In these past 40 years OMB has supplied millions of valves to major oil and gas companies worldwide. During this time OMB's name has become synonymous with absolute reliability, superior quality, and competitive pricing.

In the early 80's OMB was the first to introduce robotics in the valve manufacturing process. This included specialized equipment designed to reduce machining time, and increase the quality of the machined components.

Today OMB's commitment to innovation and continuous improvement is higher than ever. With this in mind, OMB is focused on expanding our capacity at home, opening new plants abroad, and extending our distribution network to better serve our customers.

We invite you to visit any of our facilities to meet our experienced workers and see the state of the art equipment they are using to produce the best valve money can buy.

This is our promise!

Roberto, Simone and Fabio Brevi

The Brevi family is active in the management of the operations.

Roberto Brevi, founder and chairman with Simone and Fabio managing directors.

OMB is based in Bergamo, a town 45 Km from Milan with easy access to airports, highways and seaport. Bergamo is the world center for the forged steel valves production with a large valve parts subcontracting base.





FORGED STEEL

The body and end connectors are made from forged steel bars, or closed dye forgings and engraved with the heat code and material ASTM number. Additional markings can be added upon request.

FULL AND REGULAR BORE

OMB can manufacture valves with reduced and full bore in a range of sizes. Both port types are available with threaded, socket weld, and butt weld (Sch. 40 & Sch. 80) ends.

- Full Bore - 1/4" (DN 6) through 6" (DN 300)
- Reduced Bore - 1/2" (DN 15) through 6" (DN 300).

CONSTRUCTION

OMB compact and lip seal ball valves have been designed in full compliance with the requirements set forth by BS 5351, ISO 14313, API 6D, and API 608.

INCAPSULATED SEATS

OMB's seats are set deep into the pocket providing additional protection for a longer life.

DOUBLE BODY GASKET

The two body gaskets, one in PTFE and the other in graphite materials, grant the sealing in whatever corrosive service as well give a fire safe characteristic.

TESTING TO BS6755 AND API 598

The hydrotests for seat sealing and body sealing are carried out respectively at 110% and 150% of the rated Cold Working Pressure. Low Pressure seat test is carried out at 100 p.s.i. (6 bar) with dry air. The hydrostatic seat pressure shall not exceed the seat rating.





FIRE SAFE

OMB's valves have been fully tested and certified fire safe according to BS 6755 and API 607.

METAL SEATED BALL VALVES

For a traditional ball valve, one of the most demanding service conditions involve the handling of high abrasive mediums, slurries, and corrosive liquids. A solution to this problem is the use of metal seated ball valves. OMB's metal seated ball valves use wear resistant and low friction hard overlays on the ball and seats to combat these severe conditions.

In the production of these valves, a thick layer of tungsten carbide (available from 0.12 to 1mm) is built up by shooting the carbide powder onto the hard faced surfaces using a HVOF (High Oxygen Fueled) process. Following the application of the carbide, the surfaces are machined to very tight tolerances to guarantee proper seating and sealing. OMB's metal seated ball valves are available in a variety of sizes and pressure classes.



ANTI BLOWOUT STEM

OMB's valve design prevents the stem from being blown out in the event that the gland is removed while it is under pressure.

ANTISTATIC DEVICE

This feature incorporated in every valve design, ensures electrical continuity between the body, ball and stem.



	LIP			CM		COMPACT					END ENTRY			TOP ENTRY					ENERGIZED SEATS											
	2 pcs			3 pcs		2 pcs					1 pcs			1 pcs					2 or 3 pcs											
	SW - NPT			SW - NPT		FLANGED					FLANGED			FLANGED & BUTT WELD					FLANGED & BUTT WELD											
	#800	#1500	#2500	#800	#1500	#150	#300	#600	#900	#1500	#2500	#150	#300	#600	#150	#300	#600	#800	#900	#1500	#2500	#150	#300	#600	#800	#900	#1500	#2500		
1/2"																														
3/4"																														
1"																														
1.1/2"																														
2"																														
3"																														
4"																														
6"																														
8"																														
10"																														

	LIP	CM	COMPACT	END ENTRY	TOP ENTRY	ENERGIZED SEAT
Body design	2 pieces	3 pieces	2 pices	1 pieces	1 piece	1 or 2 pieces
Body/Closure construction	Threaded and seal welded	Bolted	Bolted	Screwed cup	Bolted	Bolted
Seat design	Seat supported ball	Seat supported ball	Seat supported ball	Seat supported ball	Spring Energized seats	Spring Energized seats
Body construction	Forged	Forged	Forged	Forged	Forged	Forged
Fire Safe	Certified	Certified	Certified	Design	Design	Design
Stem	Antiblowout	Antiblowout	Antiblowout	Antiblowout	Antiblowout	Antiblowout
ASME Classes	800,1500,2500	800,1500	150 to 2500	150,300,600	150 to 2500	150 to 2500
Metal Seat	Available	Available	Available	n/a	Available	Available
Lip Seal	n/a	n/a	Available	n/a	Available	Available



TB-800



CM 800

LIP

- 2 pieces screwed or screwed & seal welded
- Sizes 1/4" through 2"
- Bar-Stock (forging on request)
- Full and regular port
- Class 800-2000 psi WOG
- Class 1500-3700 psi WOG
- Class 2500-6000 psi WOG
- Threaded, socket weld and butt weld ends
- Fire safe tested

CM

- 3 pieces bolted
- Sizes 1/4" through 2"
- Close dye forged steel
- Full and regular port
- Gasket + o-ring or SP.W. gasket design available
- Class 800-2000 psi WOG
- Class 1500-3000 psi WOG
- Threaded, socket weld ends
- Fire safe tested





F6-C800

COMPACT

- 2 pieces side entry bolted
- Sizes 1/4" through 6"
- Forged steel (bar or closed dye)
- Full and regular Port
- Class 150
- Class 300
- Class 600
- Class 900 and 1500
- Class 2500
- Flanged and butt weld ends to ANSI and DIN std.
- Fire safe



F1-E800

END ENTRY

- One piece body with screwed-in end cup
- Sizes 1/2" through 2"
- Forged Steel
- Reduced port only
- Class 150
- Class 300
- Class 600
- Flanged to ANSI
- Fire safe design



CS-800

SWING

- 3 pieces bolted
- Sizes 1/4" through 2"
- Forged steel closed dye
- Full and regular port
- Class 800-2000 psi WOG
- Class 1500-3000 psi WOG
- Threaded, socket weld ends
- In-line Swing-out design
- Not fire safe



BTW-900

TOP ENTRY

- One piece body, top entry, bolted cover, energized seats
- Sizes 1/2" through 6"
- Close dye forged steel
- Full and regular bore
- Socket weld, butt weld ends
- Fire safe tested





LIP type

1-piece body construction.

Screwed body or Screwed and seal welded body

Forged steel construction

Standards:

- Design: ISO 17292 - ASME B16.34
- Test: BS6755 P1
- Top Flange: ISO 5211 optional
- Fire safe: API 607, British Standard BS 6755 or API 6FA among others.
- NPT thread: ASME B1.20.1
- SW: ASME B16.11
- SW + Nipples Sch 40-80 (ASME B16.25)

MAIN FEATURE

- Sizes 1/4" through 2"
- Bar-Stock (forged die on request)
- Full and Regular Port
- Class 800-2000 psi WOG
- Class 1500-3700 psi WOG
- Class 2500-6000 psi WOG
- Threaded, Socket Weld and Butt Weld Ends

LIP BALL VALVES MATERIALS

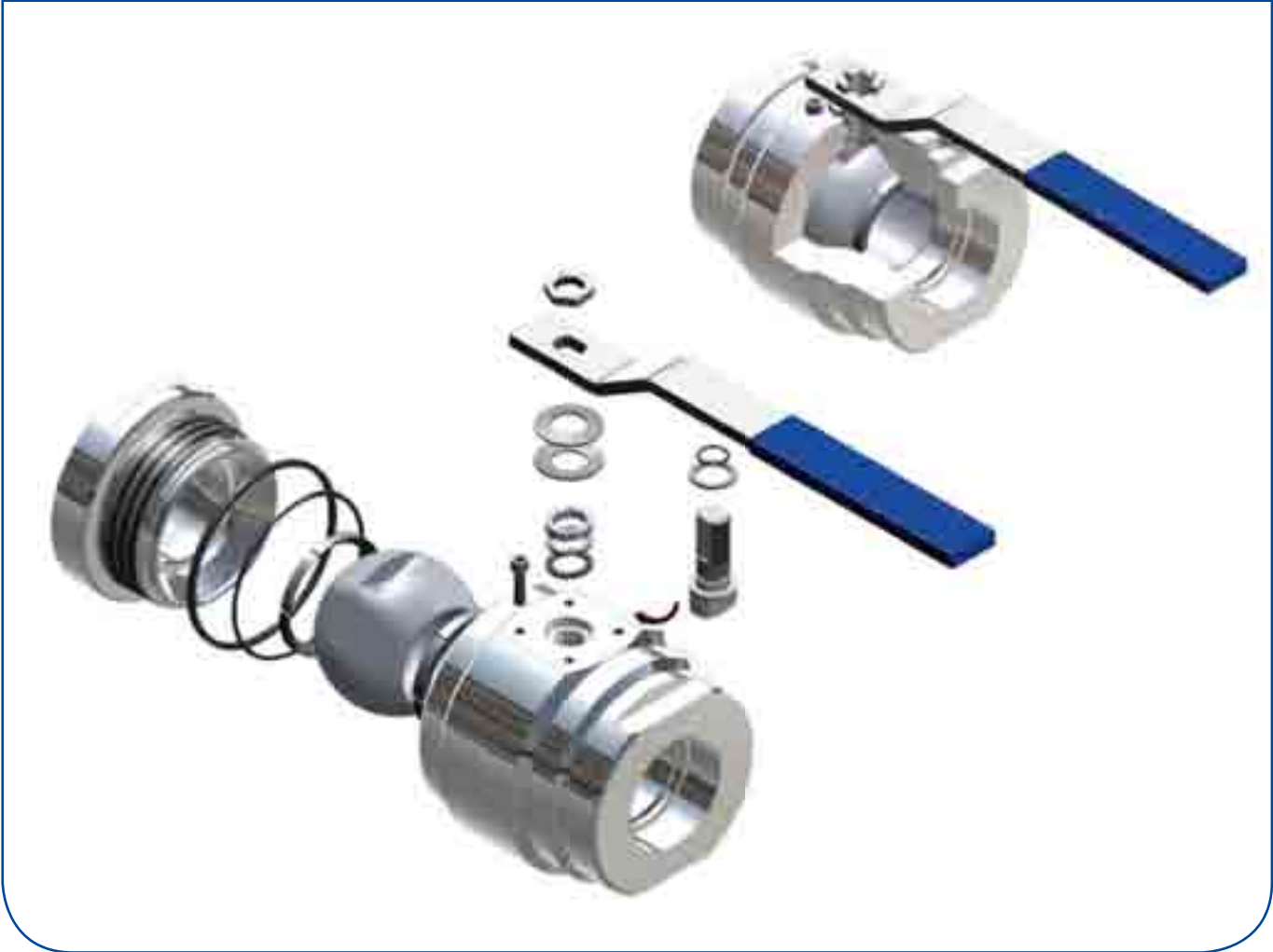

DESCRIPTION	A105/316	LF2/316	F316/316
LEVER NUT	Carbon Steel	Carbon Steel	Carbon Steel
NAMEPLATE	Aluminium	Aluminium	Aluminium
LEVER	Carbon Steel	Carbon Steel	Carbon Steel
PACKING	Graphite	Graphite	Graphite
GLAND	Stainless Steel	Stainless Steel	Stainless Steel
PACKING+STEM GASKET	PTFE+25% Fiberglass	PTFE+25% Fiberglass	PTFE+25% Fiberglass
SPRING	Harmonic Steel	Harmonic Steel	Harmonic Steel
STEM	st/st 316	st/st 316	st/st 316
END CONNECTOR	A105N	A350 LF2	A182 F316
BODY GASKET	PTFE+15% Glass	PTFE+15% Glass	PTFE+15% Glass
SEATS	PTFE+15% Glass	PTFE+15% Glass	PTFE+15% Glass
BODY	A105N	A350 LF2	A182 F316
BALL	st/st 316	st/st 316	st/st 316
FIRE SAFE GASKET	Graphite	Graphite	Graphite
STEM O-RING	FKM*	FKM*	FKM*

FKM* = Viton® or equivalent. Viton is registered trademark of DuPont Performance Elastomers



T-800/T-600

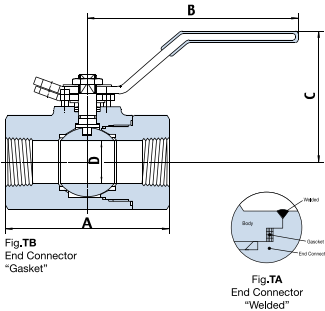

CLASS 800 REDUCED AND FULL BORE LIP TWO PIECES BAR STOCK - ISO 17292

Floating Ball Valve - Threaded and Socket Weld Ends

REDUCED BORE	T-800	-	1/2"	3/4"	1"	1 1/4"	1 1/2"	2"	-								
FULL BORE	T-600	1/4"	3/8"	1/2"	3/4"	1"	1 1/4"	1 1/2"	2"								
		mm	in.	mm	in.	mm	in.	mm	in.	mm	in.	mm	in.	mm	in.		
End to End	A	85	3.34	85	3.34	90	3.54	110	4.33	125	4.92	135	5.31	150	5.90	180	6.29
Lever	B	155	6.10	155	6.10	155	6.10	170	6.69	170	6.69	230	9.05	230	9.05	310	12.20
Center to Top	C	74	2.91	74	2.91	76	2.99	98	3.85	100	3.93	119	4.68	124	4.88	160	6.29
Ball Bore	D	10	0.39	10	0.39	14	0.55	20	0.78	25	0.98	32.5	1.27	38	1.49	51	2.00
Nipple Welded sch. 40/80/160	L	100	4"	100	4"	100	4"	100	4"	100	4"	100	4"	100	4"	100	4"

T1-800/T1-600

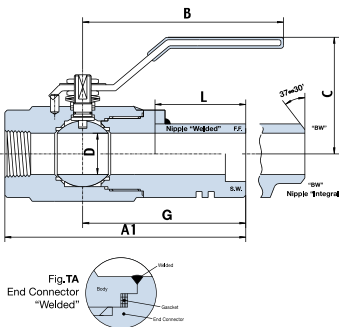

CLASS 800 REDUCED AND FULL BORE LIP TWO PIECES BAR STOCK - ISO 17292

Floating Ball Valve - Threaded and Socket Weld Ends - 1 Nipple

REDUCED BORE	T1-800	-	1/2"	3/4"	1"	1 1/4"	1 1/2"	2"	-								
FULL BORE	T1-600	1/4"	3/8"	1/2"	3/4"	1"	1 1/4"	1 1/2"	2"								
		mm	in.	mm	in.	mm	in.	mm	in.	mm	in.	mm	in.	mm	in.		
End to End	A	174	6.85	174	6.85	177	6.85	195	7.67	209	8.22	217	8.54	228	8.97	238	9.37
Lever	B	155	6.10	155	6.10	155	6.10	170	6.69	170	6.69	230	9.05	230	9.05	310	12.20
Center to Top	C	74	2.91	74	2.91	76	2.99	98	3.85	100	3.93	119	4.68	124	4.88	160	6.29
Ball Bore	D	10	0.39	10	0.39	14	0.55	20	0.78	25	0.98	32.5	1.27	38	1.49	51	2.00
Centre to End	G	131	5.51	131	5.51	132	0.56	140	5.51	146	5.75	149	5.86	156	6.15	158	6.22
Nipple Welded sch. 40/80/160	L	100	4"	100	4"	100	4"	100	4"	100	4"	100	4"	100	4"	100	4"

T2-800/T2-600

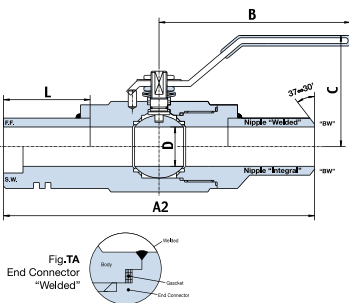

CLASS 800 REDUCED AND FULL BORE LIP TWO PIECES BAR STOCK - ISO 17292

Floating Ball Valve - Threaded and Socket Weld Ends - 2 Nipples

REDUCED BORE	T2-800	-	1/2"	3/4"	1"	1 1/4"	1 1/2"	2"	-								
FULL BORE	T2-600	1/4"	3/8"	1/2"	3/4"	1"	1 1/4"	1 1/2"	2"								
		mm	in.	mm	in.	mm	in.	mm	in.	mm	in.	mm	in.	mm	in.		
End to End	A	263	10.33	263	10.33	264	10.42	281	11.01	293	11.51	300	11.82	312	12.30	316	12.44
Lever	B	155	6.10	155	6.10	155	6.10	170	6.69	170	6.69	230	9.05	230	9.05	310	12.20
Center to Top	C	74	2.91	74	2.91	76	2.99	98	3.85	100	3.93	119	4.68	124	4.88	160	6.29
Ball Bore	D	10	0.39	10	0.39	14	0.55	20	0.78	25	0.98	32.5	1.27	38	1.49	51	2.00
Nipple Welded sch. 40/80/160	L	100	4"	100	4"	100	4"	100	4"	100	4"	100	4"	100	4"	100	4"

*In case of T2 design: length "A" ± 6

psi WOG - Hydrostatic body test pressure 210 bar @ 38°C - 3000 psi @ 100 F° - Hydrostatic seat test pressure 155 bar @ 38°C - 2200 psi @ 100 F°
 Max working pressure 140 bar @ 38°C - 2000 psi @ 100 F° - Mat: Body Carbon Steel - RTFE

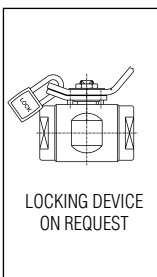

SOCKET WELD DIMENSION	MOUNTING PAD ISO 5211	6		10		15		20		25		32		40		50	
		1/4	3/8	1/2	3/4	1	1 1/4	1 1/2	2	mm	in.	mm	in.	mm	in.	mm	in.
D	E	mm	in.	mm	in.	mm	in.	mm	in.	mm	in.	mm	in.	mm	in.	mm	in.
		11.1	0.44	11.1	0.44	12.7	0.5	14.5	0.57	16.0	0.63	17.5	0.69	19.0	0.75	22.0	0.86
M	N	mm	in.	mm	in.	mm	in.	mm	in.	mm	in.	mm	in.	mm	in.	mm	in.
		14.2	0.555	17.60	0.690	21.8	0.855	27.02	1.067	33.9	1.330	42.7	1.675	48.8	1.915	61.2	2.406
		M5		M5		M5		M5		M5		M5		M5		M5	
		1.41	36	1.41	36	1.41	36	1.41	36	1.65	42	1.96	50	1.96	50	2.75	70

(1) Please consult the factory. Note. For dimensions and weights in larger sizes consult the factory. Dimensions C, D, E and weights are subject to change without notice.



T-R900/T-900

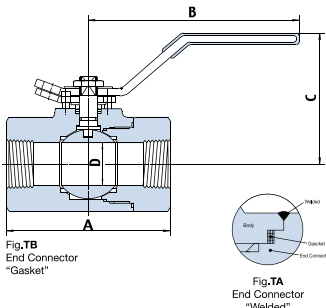

CLASS 1500 REDUCED AND FULL BORE LIP TWO PIECES BAR STOCK - ASME B16.34

Floating Ball Valve - Threaded and Socket Weld Ends

REDUCED BORE	T-R900	-	1/2"	3/4"	1"	1 1/4"	1 1/2"	2"	-								
FULL BORE	T-900	1/4"	3/8"	1/2"	3/4"	1"	1 1/4"	1 1/2"	2"								
		mm	in.	mm	in.	mm	in.	mm	in.	mm	in.	mm	in.	mm	in.		
End to End	A	85	3.34	85	3.34	90	3.54	110	4.33	125	4.92	135	5.31	150	5.90	180	6.29
Lever	B	155	6.10	155	6.10	155	6.10	170	6.69	170	6.69	230	9.05	230	9.05	310	12.20
Center to Top	C	74	2.91	74	2.91	76	2.99	98	3.85	100	3.93	119	4.68	124	4.88	160	6.29
Ball Bore	D	10	0.39	10	0.39	14	0.55	20	0.78	25	0.98	32.5	1.27	38	1.49	51	2.00
Nipple Welded sch. 40/80/160	L	100	4"	100	4"	100	4"	100	4"	100	4"	100	4"	100	4"	100	4"

T1-R900/T1-900

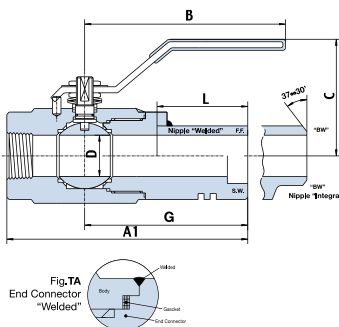

CLASS 1500 REDUCED AND FULL BORE LIP TWO PIECES BAR STOCK - ASME B16.34

Floating Ball Valve - Threaded and Socket Weld Ends - 1 Nipple

REDUCED BORE	T1-R900	-	1/2"	3/4"	1"	1 1/4"	1 1/2"	2"	-								
FULL BORE	T1-900	1/4"	3/8"	1/2"	3/4"	1"	1 1/4"	1 1/2"	2"								
		mm	in.	mm	in.	mm	in.	mm	in.	mm	in.	mm	in.	mm	in.		
End to End	A	174	6.85	174	6.85	177	6.85	195	7.67	209	8.22	217	8.54	231	9.09	160	6.29
Lever	B	155	6.10	155	6.10	155	6.10	170	6.69	170	6.69	230	9.05	230	9.05	310	12.20
Center to Top	C	74	2.91	74	2.91	76	2.99	98	3.85	100	3.93	119	4.68	124	4.88	160	6.29
Ball Bore	D	10	0.39	10	0.39	14	0.55	20	0.78	25	0.98	32.5	1.27	38	1.49	51	2.00
Centre to end	G	131	5.51	131	5.51	132	0.56	140	5.51	146	5.75	149	5.86	156	6.15	158	6.22
Nipple Welded sch. 40/80/160	L	100	4"	100	4"	100	4"	100	4"	100	4"	100	4"	100	4"	100	4"

T2-R900/T2-900

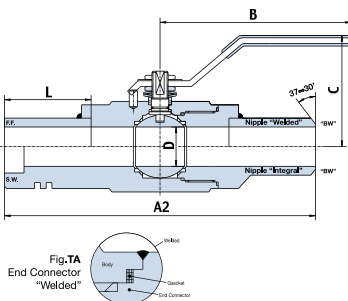

CLASS 1500 REDUCED AND FULL BORE LIP TWO PIECES BAR STOCK - ASME B16.34

Floating Ball Valve - Threaded and Socket Weld Ends - 2 Nipples

REDUCED BORE	T2-R900	-	1/2"	3/4"	1"	1 1/4"	1 1/2"	2"	-								
FULL BORE	T2-900	1/4"	3/8"	1/2"	3/4"	1"	1 1/4"	1 1/2"	2"								
		mm	in.	mm	in.	mm	in.	mm	in.	mm	in.	mm	in.	mm	in.		
End to End	A	263	10.33	263	10.33	264	10.42	281	11.01	293	11.51	300	11.82	312	12.30	316	12.44
Lever	B	155	6.10	155	6.10	155	6.10	170	6.69	170	6.69	230	9.05	230	9.05	310	12.20
Center to Top	C	74	2.91	74	2.91	76	2.99	98	3.85	100	3.93	119	4.68	124	4.88	160	6.29
Ball Bore	D	10	0.39	10	0.39	14	0.55	20	0.78	25	0.98	32.5	1.27	38	1.49	51	2.00
Nipple Welded sch. 40/80/160	L	100	4"	100	4"	100	4"	100	4"	100	4"	100	4"	100	4"	100	4"

*In case of T2 design: length "A" ± 6

CLASS 1500 - 3700 psi WOG - Hydrostatic body test pressure 395 bar @ 38°C - 5650 psi @ 100 F° - Hydrostatic seat test pressure 285 bar @ 38°C - 4075 psi @ 100 F°
 Max working pressure 225 bar @ 38°C - 3700 psi @ 100 F° - Mat: Body Carbon Steel - Seat Derlin

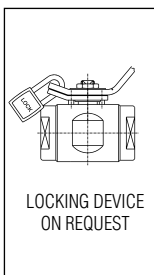

		6		10		15		20		25		32		40		50		
		1/4		3/8		1/2		3/4		1		1 1/4		1 1/2		2		
SOCKET WELD DIMENSION		D	11.1	0.44	11.1	0.44	12.7	0.5	14.5	0.57	16.0	0.63	17.5	0.69	19.0	0.75	22.0	0.86
		E	14.2	0.555	17.60	0.690	21.8	0.855	27.02	1.067	33.9	1.330	42.7	1.675	48.8	1.915	61.2	2.406
MOUNTING PAD ISO 5211		M	M5		M5		M5		M5		M5		M5		M5		M5	
		N	1.41	36	1.41	36	1.41	36	1.41	36	1.65	42	1.96	50	1.96	50	2.75	70

(1) Please consult the factory. Note. For dimensions and weights in larger sizes consult the factory. Dimensions C, D, E and weights are subject to change without notice.



T-R2500/T-2500

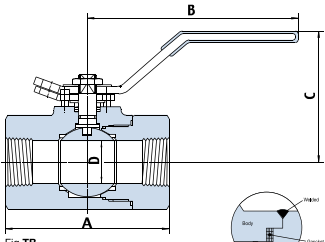

Fig.TB
End Connector
"Gasket"

Fig.TA
End Connector
"Welded"

CLASS 2500 REDUCED AND FULL BORE LIP TWO PIECES BAR STOCK - ASME B.34

Floating Ball Valve - Threaded and Socket Weld Ends

REDUCED BORE	T-R2500	-	1/2"	3/4"	1"	1 1/4"	1 1/2"	2"	-		
FULL BORE	T-2500	1/4"	3/8"	1/2"	3/4"	1"	1 1/4"	1 1/2"	2"		
		mm	in.	mm	in.	mm	in.	mm	in.	mm	in.
End to End	A			110	4.33	125	4.99	135	5.31		
Lever	B			170	6.69	230	9.05	230	9.05		
Center to Top	C			95	3.74	110	4.33	125	4.92		
Ball Bore	D			14	0.55	20	0.78	25	0.98		
Centre to End	G			142	5.59	148	5.82	151	5.94		
Nipple Welded sch. 40/80/160	L			100	4"	100	4"	100	4"		

T1-R2500/T1-2500

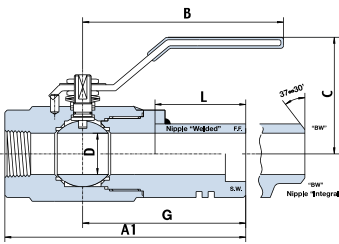

Fig.TA
End Connector
"Welded"

CLASS 2500 REDUCED AND FULL BORE LIP TWO PIECES BAR STOCK - ASME B.34

Floating Ball Valve - Threaded and Socket Weld Ends - 1 Nipple

REDUCED BORE	T1-R2500	-	1/2"	3/4"	1"	1 1/4"	1 1/2"	2"	-		
FULL BORE	T1-2500	1/4"	3/8"	1/2"	3/4"	1"	1 1/4"	1 1/2"	2"		
		mm	in.	mm	in.	mm	in.	mm	in.	mm	in.
End to End	A			197	7.75	211	8.30	219	8.62		
Lever	B			170	6.69	230	9.05	230	9.05		
Center to Top	C			95	3.74	110	4.33	125	4.92		
Ball Bore	D			14	0.55	20	0.78	25	0.98		
Centre to End	G			142	5.59	148	5.82	151	5.94		
Nipple Welded sch. 40/80/160	L			100	4"	100	4"	100	4"		

T2-R2500/T2-2500

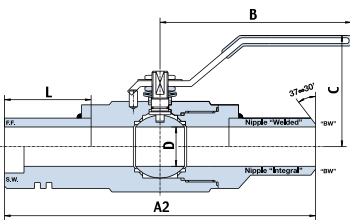

Fig.TA
End Connector
"Welded"

CLASS 2500 REDUCED AND FULL BORE LIP TWO PIECES BAR STOCK - ASME B.34

Floating Ball Valve - Threaded and Socket Weld Ends - 2 Nipple

REDUCED BORE	T2-R2500	-	1/2"	3/4"	1"	1 1/4"	1 1/2"	2"	-		
FULL BORE	T2-2500	1/4"	3/8"	1/2"	3/4"	1"	1 1/4"	1 1/2"	2"		
		mm	in.	mm	in.	mm	in.	mm	in.	mm	in.
End to End	A			284	11.81	296	11.65	303	11.90		
Lever	B			170	6.69	230	9.05	230	9.05		
Center to Top	C			95	3.74	110	4.33	125	4.92		
Ball Bore	D			14	0.55	20	0.78	25	0.98		
Centre to End	G			142	5.59	148	5.82	151	5.94		
Nipple Welded sch. 40/80/160	L			100	4"	100	4"	100	4"		

*In case of T2 design: length "A" ± 6

CLASS 2500 - 6000 psi WOG - Hydrostatic body test pressure 630 bar @ 38°C - 9000 psi @ 100 F° - Hydrostatic seat test pressure 462 bar @ 38°C - 6600 psi @ 100 F°

Max working pressure 420 bar @ 38°C - 6000 psi @ 100 F° - Mat: Body Carbon Steel - Seat Derlin

		6		10		15		20		25		32		40		50		
		1/4	3/8	1/2	3/4	1	1 1/4	1 1/2	2									
SOCKET WELD DIMENSION		D	11.1	0.44	11.1	0.44	12.7	0.5	14.5	0.57	16.0	0.63	17.5	0.69	19.0	0.75	22.0	0.86
		E	14.2	0.555	17.60	0.690	21.8	0.855	27.02	1.067	33.9	1.330	42.7	1.675	48.8	1.915	61.2	2.406
MOUNTING PAD ISO 5211		M	M5		M5		M5		M5		M5		M5		M5		M5	
		N	1.41	36	1.41	36	1.41	36	1.41	36	1.65	42	1.96	50	1.96	50	2.75	70

(1) Please consult the factory. Note. For dimensions and weights in larger sizes consult the factory. Dimensions C, D, E and weights are subject to change without notice.



*T2A-R2500
WITH INTEGRAL FIN EXTENSIONS*

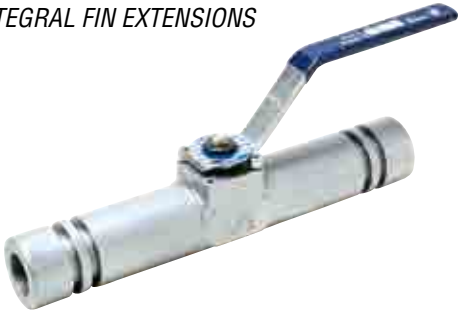

T2B-R900



T1B-R900



CLOSE DYE FORGINGS: TB-900



TB-600 IN SS E CS



TB-800 IN ASTM Ar82 F53



OVAL MANDWHEEL



STANDARD LEVER





COMPACT Type

2-piece body construction.

End entry: 1-piece body construction with screwed end plug.

Forged steel construction

Standards:

- Design: ISO 17292 - ASME B16.34
- Test: ASME B16.34
- Fire safe: API 607, British Standard BS 6755 or API 6FA among others.
- Top Flange: ISO 5211 optional
- Flanges: ASME B16.5
- Face to Face: ASME B16.10 and special design

CONSTRUCTION

- Sizes 1/4" through 6"
- Forged Steel
- Full and Regular Port
- Class 150
- Class 300
- Class 600
- Class 900 and 1500
- Flanged ends to integral flanged

COMPACT BALL VALVES MATERIALS

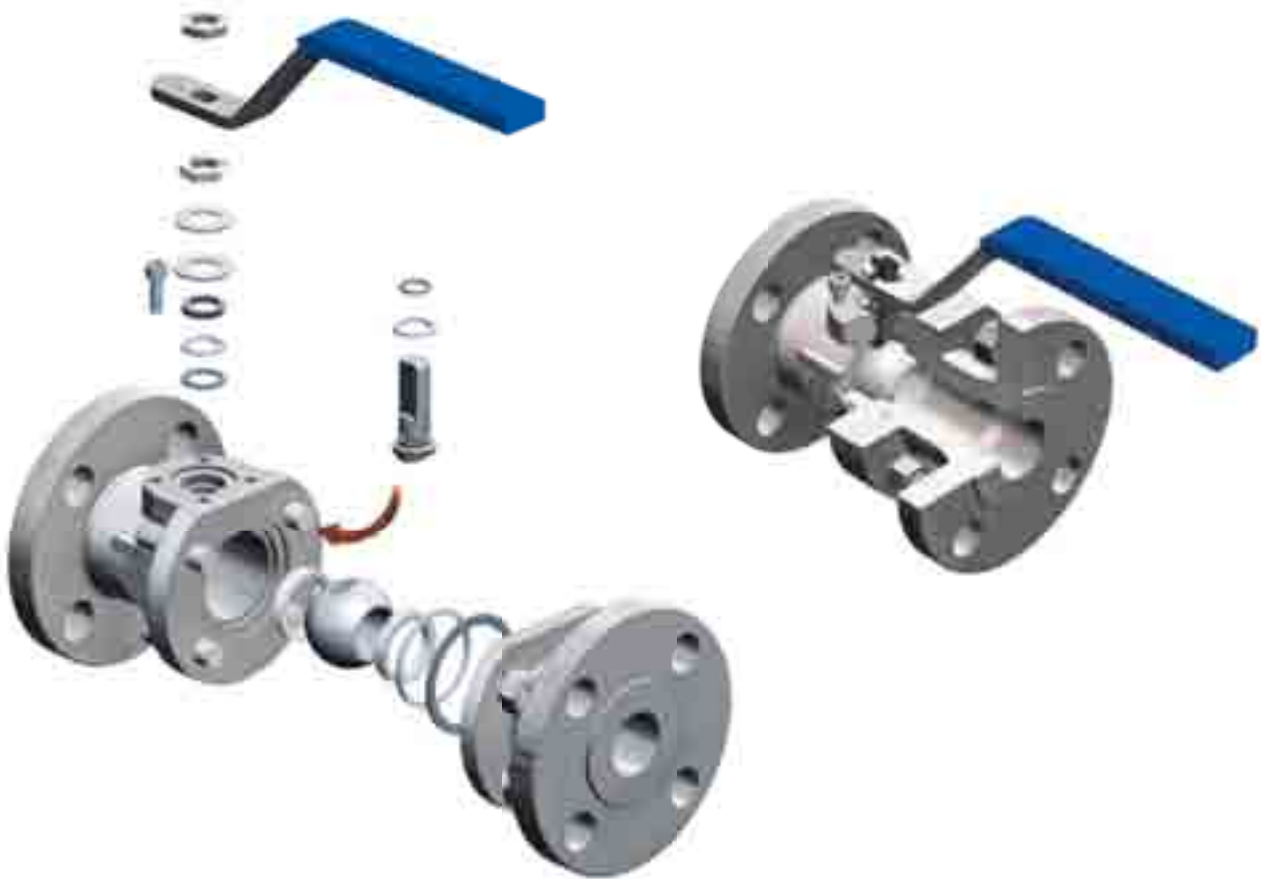

DESCRIPTION	A105/316	LF2/316	F316/316
LEVER NUT	Carbon Steel	Carbon Steel	Carbon Steel
NAMEPLATE	Aluminium	Aluminium	Aluminium
LEVER	Carbon Steel	Carbon Steel	Carbon Steel
PACKING	Graphite	Graphite	Graphite
GLAND	Stainless Steel	Stainless Steel	Stainless Steel
PACKING+STEM GASKET	PTFE+25% Fiberglass	PTFE+25% Fiberglass	PTFE+25% Fiberglass
BOLTS	A193 B7	A320 L7	A193 B8
SPRING	Harmonic Steel	Harmonic Steel	Harmonic Steel
STEM	st/st 316	st/st 316	st/st 316
END CONNECTOR	A105N	A350 LF2	A182 F316
BODY GASKET	PTFE+15% Glass	PTFE+15% Glass	PTFE+15% Glass
SEATS	PTFE+15% Glass	PTFE+15% Glass	PTFE+15% Glass
BODY	A105N	A350 LF2	A182 F316
BALL	st/st 316	st/st 316	st/st 316
FIRE SAFE GASKET	Graphite	Graphite	Graphite
STEM O-RING	FKM*	FKM*	FKM*

FKM* = Viton® or equivalent. Viton is registered trademark of DuPont Performance Elastomers



F1-C-800

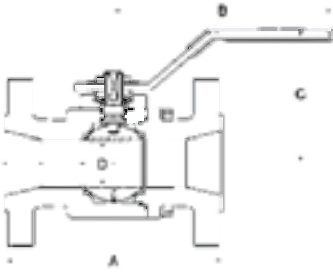

CLASS 150 REDUCED BORE SIDE TWO PIECE BALL VALVES BODY - ISO 17292

Integral Flanged - End According to ANSI 16.10

REDUCED BORE	F1-C-800	1/2" x 3/8"		3/4" x 1/2"		1" x 3/4"		1 1/2" x 1 1/4"		2" x 1 1/2"		3" x 2"		4" x 3"		6" x 4"	
		mm	in.	mm	in.	mm	in.	mm	in.	mm	in.	mm	in.	mm	in.	mm	in.
End to End	A	108	4.3	117	4.6	127	5	165	6.5	178	7.0	203	8.0	229	9.0	394	15.5
Lever	B	155	6.1	140	5.5	170	6.7	170	6.7	230	9.1	310	12.2	400	15.7	500	19.7
Center to Top	C	75	3.0	98	3.9	98	3.9	100	3.9	130	5.1	155	6.1	150	5.9	190	7.5
Ball Bore	D	11.1	0.4	14.2	0.6	20.5	0.8	31.7	1.2	38	1.5	51	2.0	76	3.0	102	4.0

*Gear operator suggest

F3-C-800

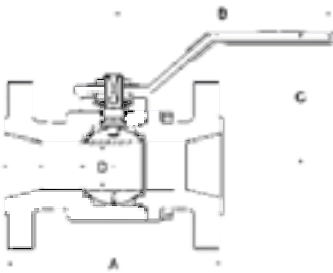

CLASS 300 REDUCED BORE SIDE TWO PIECE BALL VALVES BODY - ISO 17292

Integral Flanged - End According to ANSI 16.10

REDUCED BORE	F3-C-800	1/2" x 3/8"		3/4" x 1/2"		1" x 3/4"		1 1/2" x 1 1/4"		2" x 1 1/2"		3" x 2"		4" x 3"		6" x 4"	
		mm	in.	mm	in.	mm	in.	mm	in.	mm	in.	mm	in.	mm	in.	mm	in.
End to End	A	140	5.5	152	6.0	165	6.5	190	7.5	216	8.5	283	11.1	305	12.0	403	15.9
Lever	B	155	6.1	155	6.1	170	6.7	170	6.7	230	9.1	310	12.2	400	15.7	500	19.7
Center to Top	C	75	3.0	77	3.0	98	3.9	100	3.9	130	5.1	155	6.1	190	7.5	190	7.5
Ball Bore	D	11.1	0.4	14.2	0.6	20.5	0.8	31.7	1.2	38	1.5	51	2.0	76	3.0	102	4.0

*Gear operator suggest

F6-C-800

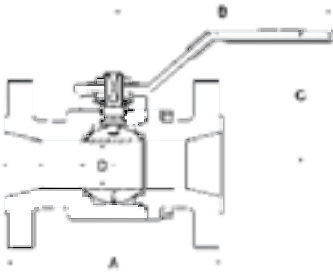

CLASS 600 REDUCED BORE SIDE TWO PIECE BALL VALVES BODY - ISO 17292

Integral Flanged - End According to ANSI 16.10

REDUCED BORE	F6-C-800	1/2" x 3/8"		3/4" x 1/2"		1" x 3/4"		1 1/2" x 1 1/4"		2" x 1 1/2"		3" x 2"		4" x 3"		6" x 4"	
		mm	in.	mm	in.	mm	in.	mm	in.	mm	in.	mm	in.	mm	in.	mm	in.
End to End	A	165	6.5	191	7.5	216	8.5	241	9.5	292	11.5	356	14.0	432	17.0	559	22.0
Lever	B	155	6.1	155	6.1	170	6.7	170	6.7	230	9.1	310	12.2	400	15.7	500	19.7
Center to Top	C	75	3.0	77	3.0	98	3.9	105	4.1	130	5.1	155	6.1	182	7.2	208	8.2
Ball Bore	D	11.1	0.4	14.2	0.6	20.5	0.8	31.7	1.2	38	1.5	51	2.0	76	3.0	102	4.0

*Gear operator suggest

F9-C-R900

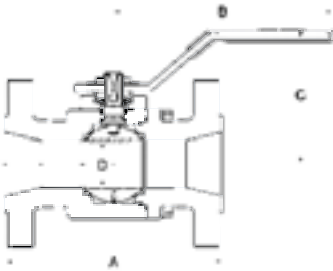

CLASS 1500 REDUCED BORE SIDE TWO PIECE BALL VALVES BODY - ASME B16.34

Integral Flanged - End According to ANSI 16.10

REDUCED BORE	F9-C-R900	1/2 x 3/8		3/4 x 1/2		1 x 3/4		1 1/2 x 1 1/4		2 x 1 1/2		3 x 2		4 x 3		6 x 4	
		mm	in.	mm	in.	mm	in.	mm	in.	mm	in.	mm	in.	mm	in.	mm	in.
End to End	A	216	8.5	229	9.0	254	10.0	305	12.0	368	14.5	-	-	-	-	-	-
Lever	B	170	6.7	170	6.7	170	6.7	230	9.1	310	12.2	-	-	-	-	-	-
Center to Top	C	95	3.7	95	3.7	98	3.9	120	4.7	155	6.1	-	-	-	-	-	-
Ball Bore	D	11.1	0.4	14.2	0.6	20.5	0.8	31.7	1.2	38	1.5	-	-	-	-	-	-

Weight figures are relevant to flanged end valves. (1) Please consult the factory. Note. For dimensions and weights in larger sizes consult the factory. Dimensions C, D, E and weights are subject to change without notice.



COMPACT BALL VALVES



F1-C-600

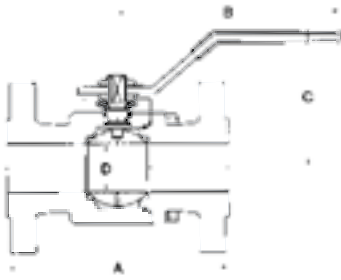

CLASS 150 FULL BORE SIDE TWO PIECE BALL VALVES BODY - ISO 17292

Integral Flanged - End According to ANSI 16.10

FULL BORE	F1-C-600	1/2"		3/4"		1"		1 1/2"		2"		3"		4"		6"	
		mm	in.	mm	in.	mm	in.	mm	in.	mm	in.	mm	in.	mm	in.	mm	in.
End to End	A	108	4.3	117	4.6	127	5	165	6.5	178	7.0	203	8.0	229	9.0	394	15.5
Lever	B	155	6.1	170	6.7	170	6.7	230	9.1	310	12.2	400	15.7	500	19.7	**	**
Center to Top	C	75	3.0	98	3.9	100	3.9	135	5.3	155	6.1	150	5.9	190	7.5	190	7.5
Ball Bore	D	14.2	0.6	20.5	0.8	25.4	1.0	38	1.5	51	2.0	76	3.0	102	4.0	102	4.0

*Gear operator suggest

F3-C-600

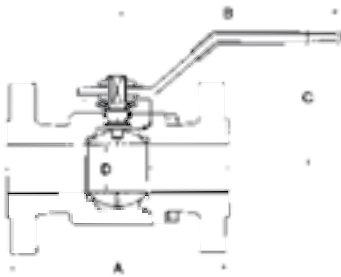

CLASS 300 FULL BORE SIDE TWO PIECE BALL VALVES BODY - ISO 17292

Integral Flanged - End According to ANSI 16.10

FULL BORE	F3-C-600	1/2"		3/4"		1"		1 1/2"		2"		3"		4"		6"	
		mm	in.	mm	in.	mm	in.	mm	in.	mm	in.	mm	in.	mm	in.	mm	in.
End to End	A	140	5.5	153	6.0	165	6.5	191	7.5	216	8.5	283	11.1	305	12.0	**	**
Lever	B	155	6.1	170	6.7	170	6.7	230	9.1	310	12.2	400	15.7	**	**	**	**
Center to Top	C	76	3.0	98	3.9	100	3.9	135	5.3	155	6.1	150	5.9	182	7.2	**	**
Ball Bore	D	14.2	0.6	20.5	0.8	25.4	1.0	38	1.5	51	2.0	76	3.0	102	4.0	**	**

*Gear operator suggest

F6-C-600

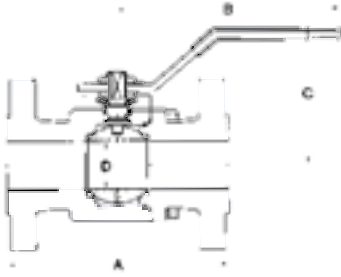

CLASS 600 FULL BORE SIDE TWO PIECE BALL VALVES BODY - ISO 17292

Integral Flanged - End According to ANSI 16.10

FULL BORE	F6-C-600	1/2"		3/4"		1"		1 1/2"		2"		3"		4"		6"	
		mm	in.	mm	in.	mm	in.	mm	in.	mm	in.	mm	in.	mm	in.	mm	in.
End to End	A	165	6.5	191	7.5	216	8.5	241	9.5	292	11.5	356	14.0	432	17.0	**	**
Lever	B	155	6.1	170	6.7	170	6.7	230	9.1	310	12.2	450	17.7	**	**	**	**
Center to Top	C	76	3.0	98	3.9	100	3.9	135	5.3	155	6.1	200	7.9	244	9.6	**	**
Ball Bore	D	14.2	0.6	20.5	0.8	25.4	1.0	38	1.5	51	2.0	76	3.0	102	4.0	**	**

*Gear operator suggest

F9-C-900

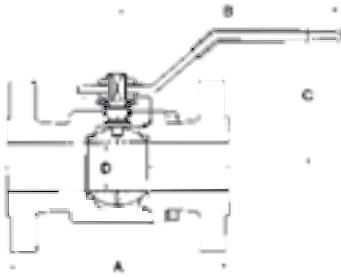

CLASS 1500 FULL BORE SIDE TWO PIECE BALL VALVES BODY - ASME B16.34

Integral Flanged - End According to ANSI 16.10

FULL BORE	F9-C-900	1/2"		3/4"		1"		1 1/2"		2"		3"		4"		6"	
		mm	in.	mm	in.	mm	in.	mm	in.	mm	in.	mm	in.	mm	in.	mm	in.
End to End	A	216	8.5	229	9.0	254	10.0	305	12.0	368	14.5	**	**	**	**	**	**
Lever	B	170	6.7	170	6.7	230	9.1	310	12.2	400	15.7	**	**	**	**	**	**
Center to Top	C	86	3.4	120	4.7	120	4.7	140	5.5	170	6.7	**	**	**	**	**	**
Ball Bore	D	14.2	0.6	20.5	0.8	25.4	1.0	38	1.5	51	2.0	**	**	**	**	**	**

*Gear operator suggest

Weight figures are relevant to flanged end valves. (1) Please consult the factory. Note. For dimensions and weights in larger sizes consult the factory. Dimensions C, D, E and weights are subject to change without notice.



F1-E-800

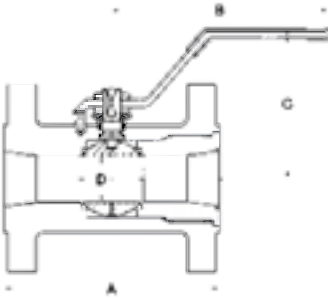

CLASS 150 REDUCED BORE END ENTRY ONE PIECE BALL VALVES BODY - ISO 17292

Integral Flanged - End According to ANSI 16.10

REDUCED BORE	F1-E-800	1/2" x 3/8"		3/4" x 1/2"		1" x 3/4"		1 1/2" x 1 1/4"		2" x 1 1/2"	
		mm	in.	mm	in.	mm	in.	mm	in.	mm	in.
End to End	A	108	4.25	118	4.62	127	5.00	165	6.50	178	7.00
Lever	B	155	6.10	155	6.10	170	6.69	230	9.05	230	9.05
Center to Top	C	74	2.91	76	2.99	98	3.85	119	4.68	130	5.11
Ball Bore	D	11.1	0.43	14.2	0.55	20.5	0.80	31.7	1.24	38	1.49

F3-E-800

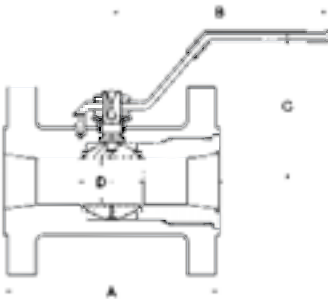

CLASS 300 REDUCED BORE END ENTRY ONE PIECE BALL VALVES BODY - ISO 17292

Integral Flanged - End According to ANSI 16.10

REDUCED BORE	F3-E-800	1/2" x 3/8"		3/4" x 1/2"		1" x 3/4"		1 1/2" x 1 1/4"		2" x 1 1/2"	
		mm	in.	mm	in.	mm	in.	mm	in.	mm	in.
End to End	A	140	5.5	153	6.0	165	6.5	191	7.5	216	8.5
Lever	B	155	6.1	155	6.1	170	6.68	230	9.05	230	9.05
Center to Top	C	74	2.91	76	2.99	98	3.85	119	4.68	130	5.11
Ball Bore	D	11.1	0.43	14.2	0.55	20.5	0.80	31.7	1.24	38	1.49

F6-E-800

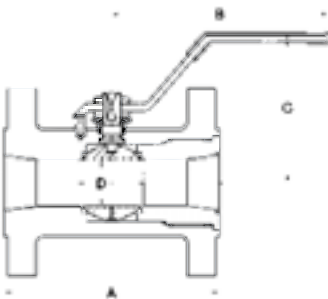

CLASS 600 REDUCED BORE END ENTRY ONE PIECE BALL VALVES BODY - ISO 17292

Integral Flanged - End According to ANSI 16.10

REDUCED BORE	F6-E-800	1/2" x 3/8"		3/4" x 1/2"		1" x 3/4"		1 1/2" x 1 1/4"		2" x 1 1/2"	
		mm	in.	mm	in.	mm	in.	mm	in.	mm	in.
End to End	A	165	6.5	191	7.5	216	8.5	241	9.5	292	11.5
Lever	B	155	6.1	155	6.1	170	6.69	230	9.05	230	9.05
Center to Top	C	74	2.91	76	2.99	98	3.85	119	4.68	130	5.11
Ball Bore	D	11.1	0.43	14.2	0.55	20.5	0.80	31.7	1.24	38	1.49

Weight figures are relevant to flanged end valves. (1) Please consult the factory. Note. For dimensions and weights in larger sizes consult the factory. Dimensions C, D, E and weights are subject to change without notice.



COMPACT BALL VALVES



SIDE ENTRY FORGED BODY



END ENTRY: 1 PIECE DESIGN



FULLY FORGED BODIES



SPECIAL DESIGN: RF X NPT



SIDE ENTRY: 1/2" & 2"



END ENTRY: 1/2" & 2"



SPECIAL LEVER CONFIGURATIONS



EXTENDES STEM





COMPACT & COMPACT SWING BALL VALVES



COMPACT Type

3-piece body construction.

Forged steel construction

Standards:

- Design: ISO 17292 - ASME B16.34
- Test: ASME B16.34
- Top Flange: ISO 5211 optional
- Fire safe: API 607, British Standard BS 6755 or API 6FA among others.
- Flanges: ASME B16.5
- NPT thread: ASME B1.20.1
- SW: ASME B16.11
- SW + Nipples Sch 40-80 (ASME B16.25)

CONSTRUCTION

- Sizes 1/4" through 2"
- Forged Steel
- Full and Regular Port
- Class 800-2000 psi WOG
- Class 1500-3700 psi WOG
- Threaded, Socket Weld Ends
- Fire Safe Tested



COMPACT & COMPACT SWING BALL VALVES MATERIALS

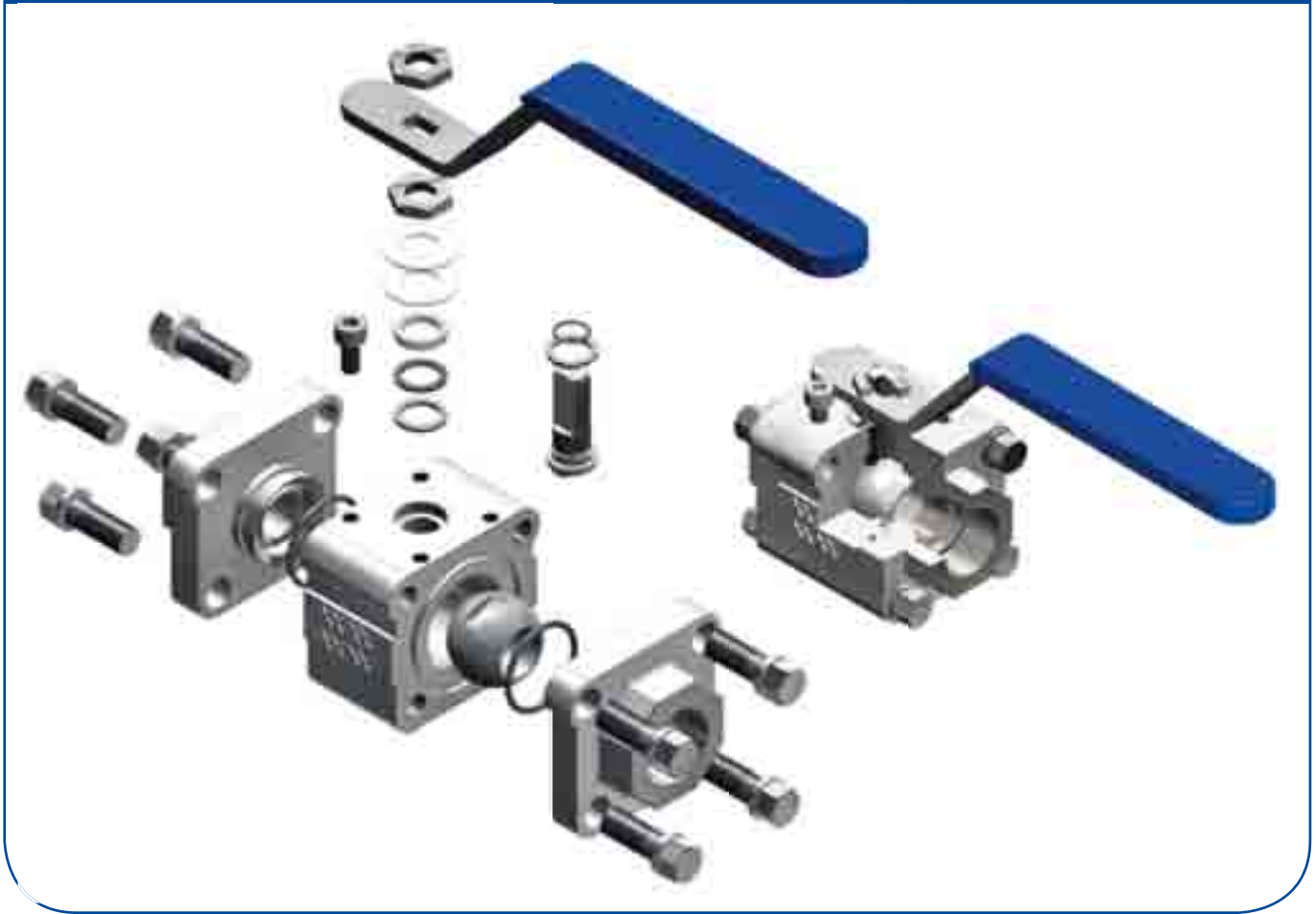

DESCRIPTION	A105/316	LF2/316	F316/316
LEVER NUT	Carbon Steel	Carbon Steel	Carbon Steel
NAMEPLATE	Aluminium	Aluminium	Aluminium
LEVER	Carbon Steel	Carbon Steel	Carbon Steel
PACKING	Graphite	Graphite	Graphite
GLAND	Stainless Steel	Stainless Steel	Stainless Steel
PACKING+STEM GASKET	PTFE+25% Fiberglass	PTFE+25% Fiberglass	PTFE+25% Fiberglass
BOLTS	A193 B7	A320 L7	A193 B8
SPRING	Harmonic Steel	Harmonic Steel	Harmonic Steel
STEM	st/st 316	st/st 316	st/st 316
END CONNECTOR	A105N	A350 LF2	A182 F316
BODY GASKET	PTFE+15% Glass	PTFE+15% Glass	PTFE+15% Glass
SEATS	PTFE+15% Glass	PTFE+15% Glass	PTFE+15% Glass
BODY	A105N	A350 LF2	A182 F316
BALL	st/st 316	st/st 316	st/st 316
FIRE SAFE GASKET	Graphite	Graphite	Graphite
STEM O-RING	FKM*	FKM*	FKM*

FKM* = Viton® or equivalent. Viton is registered trademark of DuPont Performance Elastomers



CM-800/CM-600

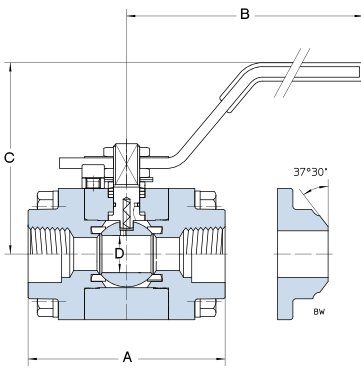

CLASS 800 REDUCED AND FULL BORE COMPACT THREE PIECES FORGED STEEL - ISO 17292

Floating Ball Valve - Threaded and Socket Weld Ends

REDUCED BORE	CM-800	-	1/2"	3/4"	1"	1 1/4"	1 1/2"	2"	-								
FULL BORE	CM-600	1/4"	3/8"	1/2"	3/4"	1"	1 1/4"	1 1/2"	2"								
		mm	in.	mm	in.	mm	in.	mm	in.	mm	in.	mm	in.	mm	in.		
End to End	A	75	2.95	75	2.95	75	2.95	87	3.42	110	4.33	120	4.72	140	5.51	160	6.29
Lever	B	155	6.10	155	6.10	155	6.10	170	6.69	170	6.69	230	9.05	230	9.05	310	12.20
Center to Top	C	72	2.83	72	2.83	76	2.99	98	3.86	100	3.94	120	4.72	130	5.12	150	5.90
Ball Bore	D	10	0.39	10	0.39	14	0.55	19	0.75	25	0.98	32.5	1.29	38	1.50	51	2.00
Socket Depth	E	11.10	0.44	11.10	0.44	12.70	0.50	14.50	0.57	16	0.63	17.50	0.69	19	0.75	22	0.87
Socket	F	14.20	0.59	17.60	0.69	21.80	0.68	27.20	1.07	33.90	1.33	42.70	1.68	48.80	1.92	61.20	2.41

CM1-800/CM1-600

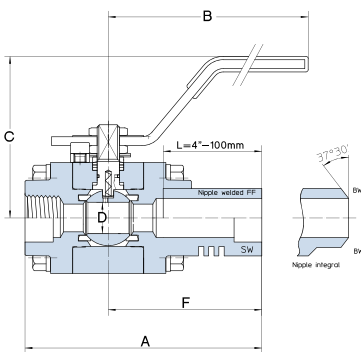

CLASS 800 REDUCED AND FULL BORE COMPACT THREE PIECES FORGED STEEL - ISO 17292

Floating Ball Valve - Threaded and Socket Weld Ends - 1 Nipple

REDUCED BORE	CM1-800	-	1/2"	3/4"	1"	1 1/4"	1 1/2"	2"	-								
FULL BORE	CM1-600	1/4"	3/8"	1/2"	3/4"	1"	1 1/4"	1 1/2"	2"								
		mm	in.	mm	in.	mm	in.	mm	in.	mm	in.	mm	in.	mm	in.		
End to End	A	164	6.46	164	6.46	162	6.38	173	6.81	194	7.64	203	7.99	221	8.70	238	9.37
Lever	B	155	6.10	155	6.10	155	6.10	170	6.69	170	6.69	230	9.05	230	9.05	310	12.20
Center to Top	C	72	2.83	72	2.83	76	2.99	98	3.86	100	3.94	120	4.72	130	5.12	150	5.90
Ball Bore	D	10	0.39	10	0.39	14	0.55	19	0.75	25	0.98	32.5	1.28	38	1.50	51	2.00
Socket Depth	E	11.10	0.44	11.10	0.44	12.70	0.50	14.50	0.57	16	0.63	17.50	0.69	19	0.75	22	0.87
Socket	F	4.20	0.56	17.60	0.69	21.80	0.68	27.20	1.07	33.90	1.33	42.70	1.68	48.80	1.92	61.20	2.41

CM2-800/CM2-600

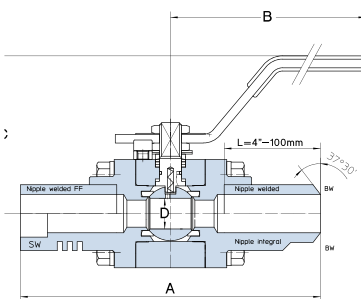

CLASS 800 REDUCED AND FULL BORE COMPACT THREE PIECES FORGED STEEL - ISO 17292

Floating Ball Valve - Threaded and Socket Weld Ends - 2 Nipples

REDUCED BORE	CM2-800	-	1/2"	3/4"	1"	1 1/4"	1 1/2"	2"	-								
FULL BORE	CM2-600	1/4"	3/8"	1/2"	3/4"	1"	1 1/4"	1 1/2"	2"								
		mm	in.	mm	in.	mm	in.	mm	in.	mm	in.	mm	in.	mm	in.		
End to End	A	253	9.96	253	9.96	250	9.84	258	10.16	278	10.94	285	11.22	302	11.89	316	12.44
Lever	B	155	6.10	155	6.10	155	6.10	170	6.69	170	6.69	230	9.05	230	9.05	310	12.20
Center to Top	C	72	2.83	72	2.83	76	2.99	98	3.86	100	3.94	120	4.72	130	5.12	150	5.90
Ball Bore	D	10	0.39	10	0.39	14	0.55	19	0.75	25	0.98	32.5	1.28	38	1.50	51	2.00
Socket Depth	E	11.10	0.44	11.10	0.44	12.70	0.50	14.50	0.57	16	0.63	17.50	0.69	19	0.75	22	0.87
Socket	F	14.20	0.56	17.60	0.69	21.80	0.86	27.20	1.07	33.90	1.33	42.70	1.68	48.80	1.92	61.20	2.41

CLASS 800 - 2000 psi WOG - Hydrostatic body test pressure 210 bar @ 38°C - 3000 psi @ 100 F° - Hydrostatic seat test pressure 155 bar @ 38°C - 2200 psi @ 100 F°
 Max working pressure 140 bar @ 38°C - 2000 psi @ 100 F° - Mat: Body Carbon Steel - RTFE

		6		10		15		20		25		32		40		50		
		1/4		3/8		1/2		3/4		1		1 1/4		1 1/2		2		
SOCKET WELD DIMENSION		D	11.1	0.44	11.1	0.44	12.7	0.5	14.5	0.57	16.0	0.63	17.5	0.69	19.0	0.75	22.0	0.86
		E	14.2	0.555	17.60	0.690	21.8	0.855	27.02	1.067	33.9	1.330	42.7	1.675	48.8	1.915	61.2	2.406
MOUNTING PAD ISO 5211		M	M5		M5		M5		M5		M5		M5		M5		M5	
		N	1.41	36	1.41	36	1.41	36	1.41	36	1.65	42	1.96	50	1.96	50	2.75	70

(1) Please consult the factory. Note. For dimensions and weights in larger sizes consult the factory. Dimensions C, D, E and weights are subject to change without notice.



COMPACT BALL VALVES



CM-R900/CM-900

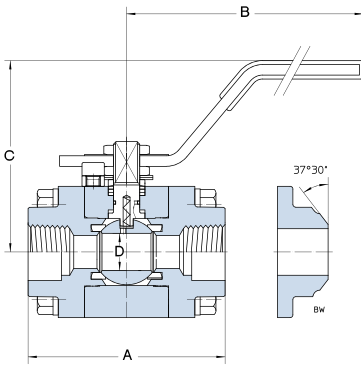

CLASS 1500 REDUCED AND FULL BORE COMPACT THREE PIECES FORGED STEEL - ASME B16.34

Floating Ball Valve - Threaded and Socket Weld Ends

REDUCED BORE	CM-R900	-	1/2"	3/4"	1"	1 1/4"	1 1/2"	2"	-								
FULL BORE	CM-900	1/4"	3/8"	1/2"	3/4"	1"	1 1/4"	1 1/2"	2"								
		mm	in.	mm	in.	mm	in.	mm	in.	mm	in.	mm	in.	mm	in.		
End to End	A	75	2.95	75	2.95	87	3.42	110	4.33	120	4.75	140	5.51	160	6.30	200	7.87
Lever	B	155	6.10	155	6.10	170	6.69	170	6.69	230	9.05	230	9.05	310	12.20	400	15.75
Center to Top	C	76	2.99	76	2.99	91	3.58	98	3.86	119	4.68	124	4.88	147	5.79	168	6.61
Ball Bore	D	10	0.39	10	0.39	14	0.55	19	0.75	25	0.98	32.5	1.28	38	1.50	51	2.00
Socket Depth	E	11.10	0.44	11.10	0.44	12.70	0.50	14.50	0.57	16	0.63	17.50	0.69	19	0.75	22	0.87
Socket	F	14.20	0.56	17.60	0.69	21.80	0.86	27.20	1.07	33.90	1.33	42.70	1.68	48.80	1.92	61.20	2.41

CM1-R900/CM1-900

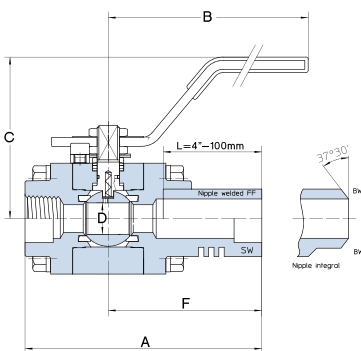

CLASS 1500 REDUCED AND FULL BORE COMPACT THREE PIECES FORGED STEEL - ASME B16.34

Floating Ball Valve - Threaded and Socket Weld Ends - 1 Nipple

REDUCED BORE	CM1-R900	-	1/2"	3/4"	1"	1 1/4"	1 1/2"	2"	-								
FULL BORE	CM1-900	1/4"	3/8"	1/2"	3/4"	1"	1 1/4"	1 1/2"	2"								
		mm	in.	mm	in.	mm	in.	mm	in.	mm	in.	mm	in.	mm	in.	mm	in.
End to End	A	164	6.46	164	6.46	175	6.89	196	7.72	204	8.03	223	8.78	241	9.49	278	10.94
Lever	B	155	6.10	155	6.10	170	6.69	170	6.69	230	9.05	230	9.05	310	12.20	400	15.75
Center to Top	C	76	2.99	76	2.99	91	3.58	98	3.86	119	4.68	124	4.88	147	5.79	168	6.61
Ball Bore	D	10	0.39	10	0.39	14	0.55	19	0.75	25	0.98	32.5	1.28	38	1.50	51	2.00
Socket Depth	E	11.10	0.44	11.10	0.44	12.70	0.50	14.50	0.57	16	0.63	17.50	0.69	19	0.75	22	0.87
Socket	F	14.20	0.56	17.60	0.69	21.80	0.86	27.20	1.07	33.90	1.33	42.70	1.68	48.80	1.92	61.20	2.41

CM2-R900/CM2-900

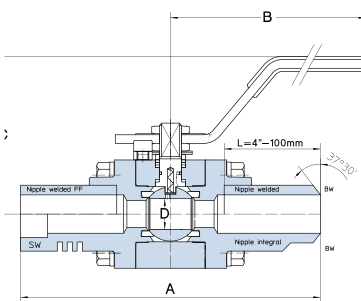

CLASS 1500 REDUCED AND FULL BORE COMPACT THREE PIECES FORGED STEEL - ASME B16.34

Floating Ball Valve - Threaded and Socket Weld Ends - 2 Nipples

REDUCED BORE	CM2-R900	-	1/2"	3/4"	1"	1 1/4"	1 1/2"	2"	-								
FULL BORE	CM2-900	1/4"	3/8"	1/2"	3/4"	1"	1 1/4"	1 1/2"	2"								
		mm	in.	mm	in.	mm	in.	mm	in.	mm	in.	mm	in.	mm	in.	mm	in.
End to End	A	253	9.96	253	9.96	262	10.31	282	11.10	288	11.33	305	12.00	322	12.68	356	14.01
Lever	B	155	6.10	155	6.10	170	6.69	170	6.69	230	9.05	230	9.05	310	12.20	400	15.75
Center to Top	C	76	2.99	76	2.99	91	3.58	98	3.86	119	4.68	124	4.88	147	5.79	168	6.61
Ball Bore	D	10	0.39	10	0.39	14	0.55	19	0.75	25	0.98	32.5	1.28	38	1.50	51	2.00
Socket Depth	E	11.10	0.44	11.10	0.44	12.70	0.50	14.50	0.57	16	0.63	17.50	0.69	19	0.75	22	0.87
Socket	F	14.20	0.56	17.60	0.69	21.80	0.86	27.20	1.07	33.90	1.33	42.70	1.68	48.80	1.92	61.20	2.41

CLASS 1500 - 3700 psi WOG - Hydrostatic body test pressure 395 bar @ 38°C - 5650 psi @ 100 F° - Hydrostatic seat test pressure 285 bar @ 38°C - 4075 psi @ 100 F°

Max working pressure 225 bar @ 38°C - 3700 psi @ 100 F° - Mat: Body Carbon Steel - Seat Derlin

		6		10		15		20		25		32		40		50		
		1/4		3/8		1/2		3/4		1		1 1/4		1 1/2		2		
SOCKET WELD DIMENSION		D	11.1	0.44	11.1	0.44	12.7	0.5	14.5	0.57	16.0	0.63	17.5	0.69	19.0	0.75	22.0	0.86
		E	14.2	0.555	17.60	0.690	21.8	0.855	27.02	1.067	33.9	1.330	42.7	1.675	48.8	1.915	61.2	2.406
MOUNTING PAD ISO 5211		M	M5		M5		M5		M5		M5		M5		M5		M5	
		N	1.41	36	1.41	36	1.41	36	1.41	36	1.65	42	1.96	50	1.96	50	2.75	70

(1) Please consult the factory. Note. For dimensions and weights in larger sizes consult the factory. Dimensions C, D, E and weights are subject to change without notice.



CS-800/CS-600

CLASS 800

REDUCED AND FULL BORE COMPACT THREE PIECES FORGED STEEL - ISO 17292
Floating Ball Valve - Threaded and Socket Weld Ends

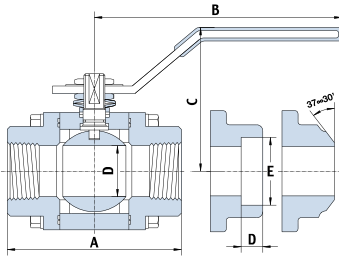

Type Compact Swing Fig. "CS"
Class 800

REDUCED BORE	CS-800	-		1/2"		3/4"		1"		1 1/4"		1 1/2"		2"		-	
FULL BORE	CS-600	1/4"		3/8"		1/2"		3/4"		1"		1 1/2"		2"		-	
		mm	in.	mm	in.	mm	in.	mm	in.	mm	in.	mm	in.	mm	in.	mm	in.
End to End	A	75	2.95	75	2.95	75	2.95	87	3.42	110	4.33	120	4.72	140	5.51	160	6.29
Lever	B	155	6.10	155	6.10	155	6.10	170	6.69	170	6.69	230	9.05	230	9.05	310	12.20
Center to Top	C	72	2.83	72	2.83	76	2.99	98	3.86	100	3.94	120	4.72	130	5.12	150	5.90
Ball Bore	D	10	0.39	10	0.39	14	0.55	19	0.75	25	0.98	32.5	1.29	38	1.50	51	2.00
Socket Depth	E	11.10	0.44	11.10	0.44	12.70	0.50	14.50	0.57	16	0.63	17.50	0.69	19	0.75	22	0.87
Socket	F	14.20	0.59	17.60	0.69	21.80	0.68	27.20	1.07	33.90	1.33	42.70	1.68	48.80	1.92	61.20	2.41

CLASS 800 - 2000 psi WOG - Hydrostatic body test pressure 210 bar @ 38°C - 3000 psi @ 100 F° - Hydrostatic seat test pressure 155 bar @ 38°C - 2200 psi @ 100 F°
Max working pressure 140 bar @ 38°C - 2000 psi @ 100 F° - Mat. Body Carbon Steel - RTFE

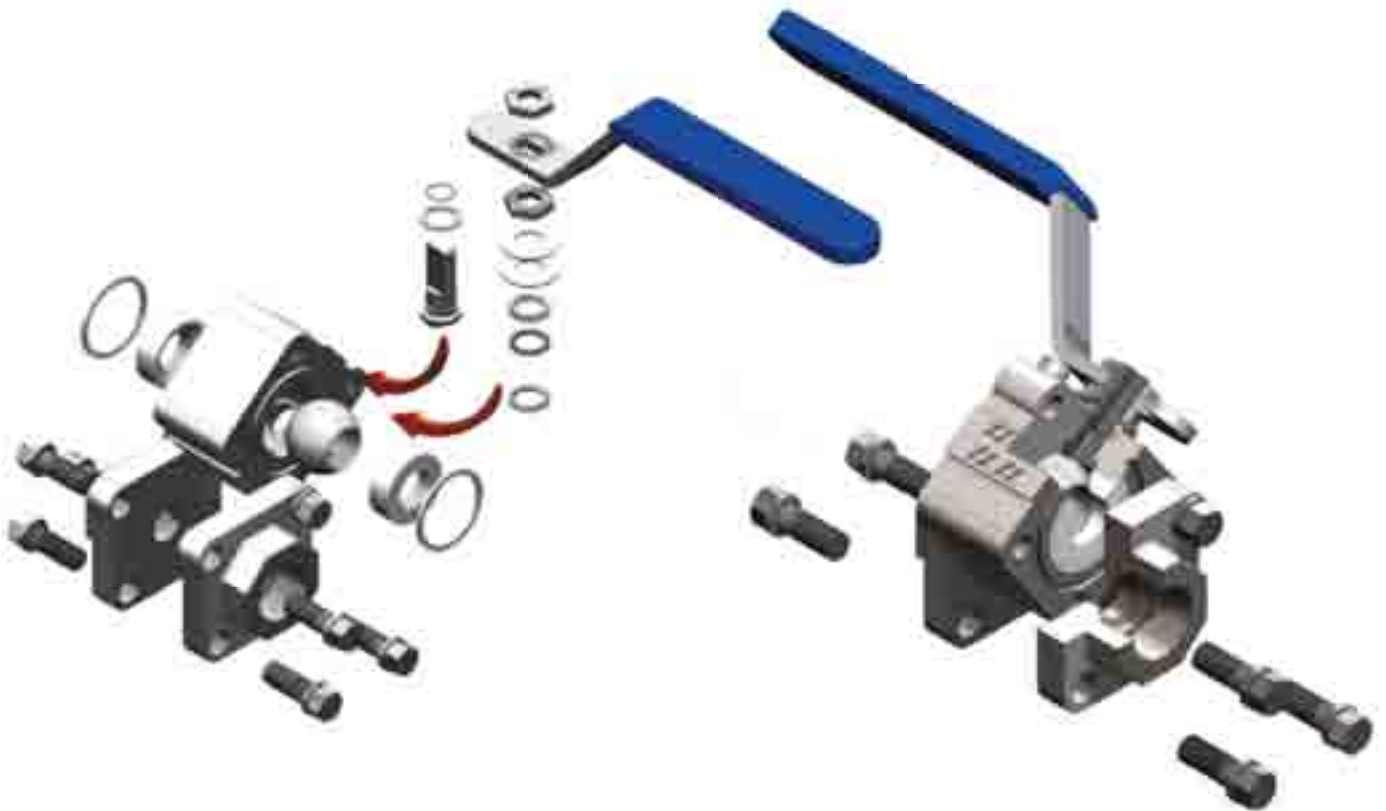

		6		10		15		20		25		32		40		50		
		1/4		3/8		1/2		3/4		1		1 1/4		1 1/2		2		
SOCKET WELD DIMENSION		D	11.1	0.44	11.1	0.44	12.7	0.5	14.5	0.57	16.0	0.63	17.5	0.69	19.0	0.75	22.0	0.86
		E	14.2	0.555	17.60	0.690	21.8	0.855	27.02	1.067	33.9	1.330	42.7	1.675	48.8	1.915	61.2	2.406
			mm	in.	mm	in.	mm	in.	mm	in.	mm	in.	mm	in.	mm	in.	mm	in.
MOUNTING PAD ISO 5211		M	M5		M5		M5		M5		M5		M5		M5		M5	
		N	1.41	36	1.41	36	1.41	36	1.41	36	1.65	42	1.96	50	1.96	50	2.75	70
			mm	in.	mm	in.	mm	in.	mm	in.	mm	in.	mm	in.	mm	in.	mm	in.

(1) Please consult the factory. Note. For dimensions and weights in larger sizes consult the factory.
Dimensions C, D, E and weights are subject to change without notice.



CM-600 FULL BORE



CM2-600



CM-800 REDUCED BORE



CM2-600



CS-800 SWINGABLE



TOT-CM-600 SPECIAL DESIGN



SPECIAL PUPS FINISH

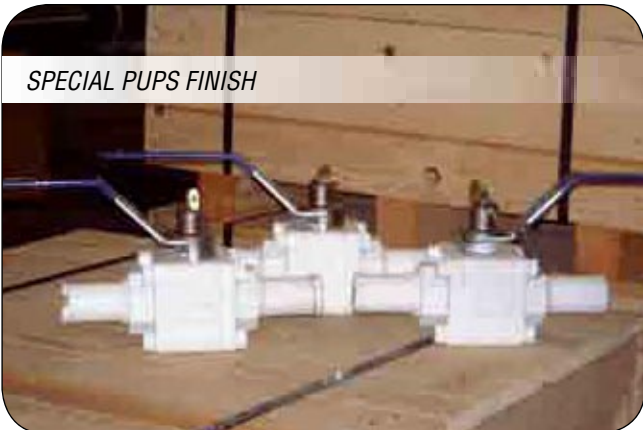

CM-800 IN LF2

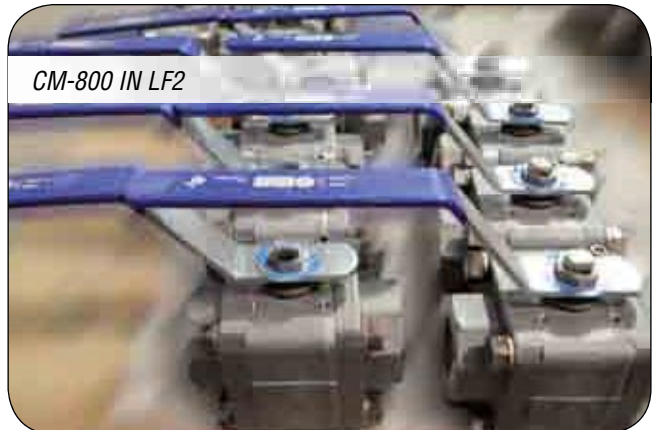



TOP ENTRY Type

One piece body construction.

Forged steel construction

Standards:

- Design: ISO 17292 - ASME B16.34
- Test: ASME B16.34
- Top Flange: ISO 5211 optional
- Fire Safe: API607, BS 6755 or API6FA
- Butt Weld ends: ASME B16.25
- SW: ASME B16.11
- NPT: thread: ASME B1.20.1

CONSTRUCTION

- Size ½" to 6"
- Forged Steel
- Full and regular port
- Class 150, 300, 600, 900, 1500
- Class 800 to OMB end to end standards
- Fire Safe design

TOP ENTRY BALL VALVES MATERIALS

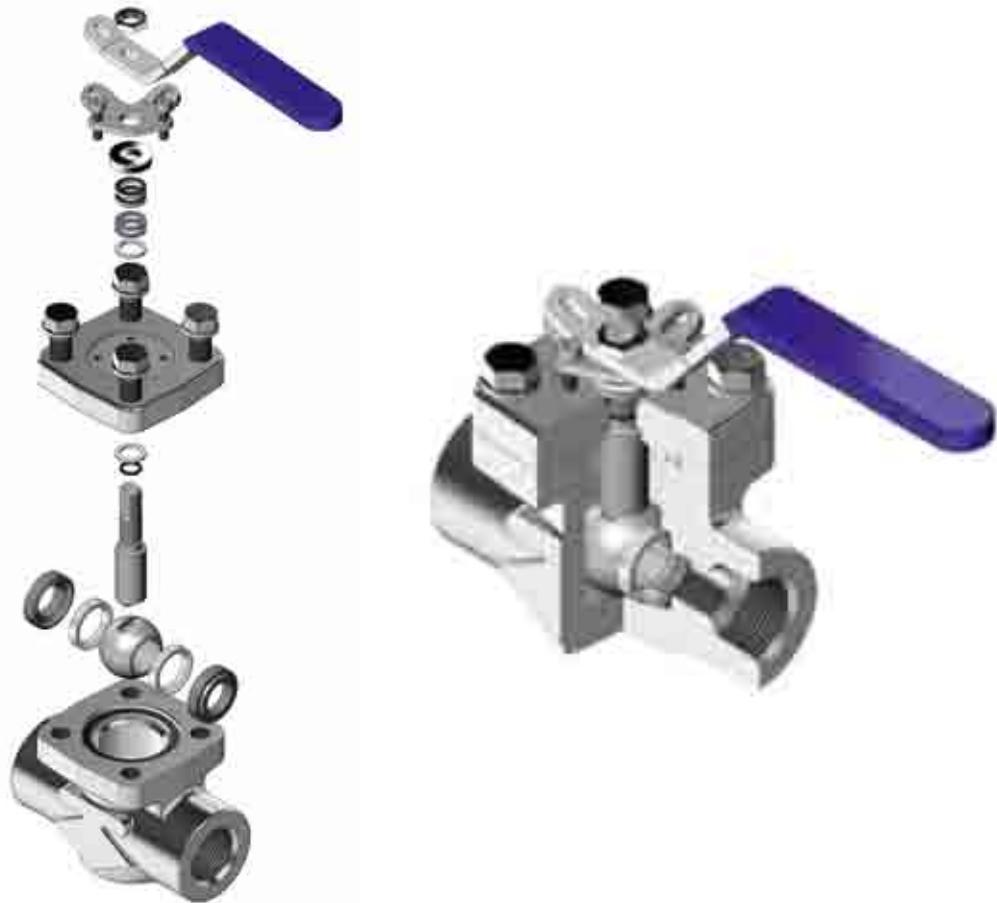

DESCRIPTION	A105/316	LF2/316	F316/316
LEVER NUT	Carbon Steel	Carbon Steel	Carbon Steel
NAMEPLATE	Aluminium	Aluminium	Aluminium
LEVER	Carbon Steel	Carbon Steel	Carbon Steel
PACKING	Graphite	Graphite	Graphite
GLAND	Stainless Steel	Stainless Steel	Stainless Steel
PACKING+STEM GASKET	PTFE+25% Fiberglass	PTFE+25% Fiberglass	PTFE+25% Fiberglass
BOLTS	A193 B7	A320 L7	A193 B8
SPRING	Harmonic Steel	Harmonic Steel	Harmonic Steel
STEM	st/st 316	st/st 316	st/st 316
END CONNECTOR	A105N	A350 LF2	A182 F316
BODY GASKET	PTFE+15% Glass	PTFE+15% Glass	PTFE+15% Glass
SEATS	PTFE+15% Glass	PTFE+15% Glass	PTFE+15% Glass
BODY	A105N	A350 LF2	A182 F316
BALL	st/st 316	st/st 316	st/st 316
FIRE SAFE GASKET	Graphite	Graphite	Graphite
STEM O-RING	FKM*	FKM*	FKM*

FKM* = Viton® or equivalent Viton is registered trademark of DuPont performance elastomers

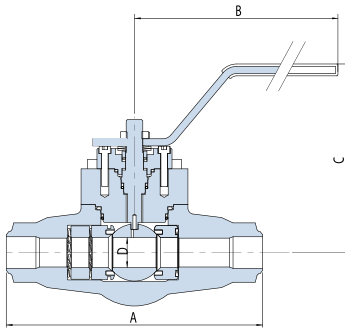

BW1-FT600

CLASS 150 FULL BORE, ONE PIECE, TOP ENTRY FORGED STEEL - ISO 17292

Integral Butt Weld Ends.

FULL BORE	BW1-FT600	1/2"		3/4"		1"		1 1/2"		2"		3"		4"		6"	
		mm	in.	mm	in.	mm	in.	mm	in.	mm	in.	mm	in.	mm	in.	mm	in.
End to End	A	140	5.50	152	5.98	165	6.50	190	7.48	216	8.50	282	11.10	305	12.00	457	21.53
Lever	B	155	6.10	170	6.70	170	6.70	230	9.10	310	12.20	450	17.70	465	18.30	-	-
Center to Top	C	81	3.20	108	4.30	120	4.70	155	6.10	185	7.30	214	8.40	255	10.00	329	13.0
Ball Bore	D	14.2	0.60	20.5	0.80	25.4	1.00	38	1.50	51	2.00	76	3.00	102	4.00	152	6.00

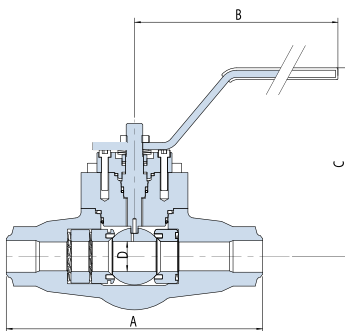
BW3-FT600

CLASS 300 FULL BORE, ONE PIECE, TOP ENTRY FORGED STEEL - ISO 17292

Integral Butt Weld Ends.

FULL BORE	BW3-FT600	1/2"		3/4"		1"		1 1/2"		2"		3"		4"		6"	
		mm	in.	mm	in.	mm	in.	mm	in.	mm	in.	mm	in.	mm	in.	mm	in.
End to End	A	140	5.50	153	6.00	165	6.50	191	7.50	216	8.50	283	11.10	305	12.00	-	-
Lever	B	155	6.10	170	6.70	170	6.70	230	9.10	310	12.10	450	17.70	-	-	-	-
Center to Top	C	81	3.20	108	4.30	120	4.70	155	6.10	185	7.30	214	8.40	255	10.00	-	-
Ball Bore	D	14.2	0.60	20.5	0.80	25.4	1.00	38	1.50	51	2.00	76	3.00	102	4.00	-	-

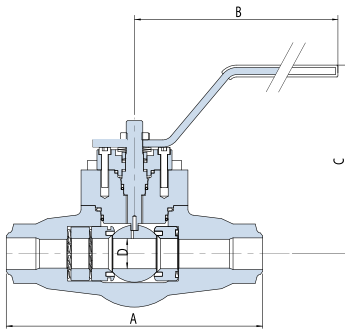
BW6-FT600

CLASS 600 FULL BORE, ONE PIECE, TOP ENTRY FORGED STEEL - ISO 17292

Integral Butt Weld Ends.

FULL BORE	BW6-FT600	1/2"		3/4"		1"		1 1/2"		2"		3"		4"		6"	
		mm	in.	mm	in.	mm	in.	mm	in.	mm	in.	mm	in.	mm	in.	mm	in.
End to End	A	165	6.50	191	7.50	216	8.50	241	9.50	292	11.50	356	14.00	432	17.00	-	-
Lever	B	155	6.10	170	6.70	170	6.70	230	9.10	310	12.20	450	17.70	-	-	-	-
Center to Top	C	81	3.20	108	4.30	120	4.70	155	6.10	185	7.30	230	9.10	152	6.00	-	-
Ball Bore	D	14.2	0.60	20.5	0.80	25.4	1.00	38	1.50	51	2.00	76	3.00	102	4.00	-	-

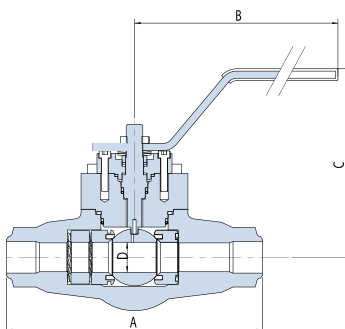
BW9-FT900

CLASS 1500 FULL BORE, ONE PIECE, TOP ENTRY FORGED STEEL - ASME B16.34

Integral Butt Weld Ends.

FULL BORE	BW9-FT900	1/2		3/4		1		1 1/2		2		3		4		6	
		mm	in.	mm	in.	mm	in.	mm	in.	mm	in.	mm	in.	mm	in.	mm	in.
End to End	A	216	8.50	229	9.00	254	10.00	305	12.00	368	14.50	-	-	-	-	-	-
Lever	B	170	6.70	170	6.70	230	9.10	310	12.20	450	17.70	-	-	-	-	-	-
Center to Top	C	103	4.10	110	4.30	139	5.50	180	7.10	240	9.40	-	-	-	-	-	-
Ball Bore	D	14.2	0.60	20.5	0.80	25.4	1.00	38	1.50	51	2.00	-	-	-	-	-	-

Weight figures are relevant to BW end valves. (1) Please consult the factory. Note. For dimensions and weights in larger sizes consult the factory. Dimensions C, D, E and weights are subject to change without notice.



FORGED TOP ENTRY FLOATING FOR JANGSU LNG



FORGED TOP ENTRY FLOATING FOR JANGSU LNG



CR-BW9-FT900



FORGED TOP ENTRY FLOATING FOR JANGSU LNG



FT800



END ENTRY: 1/2" & 2"



BW6-FT600



EXTENDED STEM



VALVES MANUFACTURING E TEST SPECIFICATIONS

STANDARD	REV	API related std	Content	
ISO 17292:2004	2004	API608/4th	Design	Metal ball valves for petroleum, petrochemical and allied industries ISO 17292:2004 specifies the requirements for a series of metal ball valves suitable for petroleum, petrochemical, natural gas plants, and related industrial applications. It covers valves of the nominal sizes DN 8, 10, 15, 20, 25, 32, 40, 50, 65, 80, 100, 150, 200, 250, 300, 350, 400, 450 and 500, corresponding to nominal pipe sizes NPS 1/4, 3/8, 1/2, 3/4, 1, 1 1/4, 1 1/2, 2, 2 1/2, 3, 4, 6, 8, 10, 12, 14, 16, 18 and 20, and is applicable for pressure designations of Class 150, 300, 600 and 800 (the last applicable only for valves with reduced bore and with threaded and socket welding end), and PN 16, 25 and 40.
BS5351 (discontinued)	1986		Design	Valve seat and body pressure/temperature ratings, the design, materials, dimensions, operation, performance, testing and marking of straightway steel ball valves having specified wall thickness, antistatic feature and fire tested design. Valves of PN 10 to PN 40 and classes 150, 300, 600 and 800 with a variety of end fittings.
ASME B16.34	2009		Design	This standard applies to new construction and covers pressure-temperature ratings, dimensions, tolerances, materials, nondestructive examination requirements, testing, and marking for cast, forged, and fabricated flanged, threaded, and welding end and wafer or flangeless valves of steel, nickel-base alloys, and other alloys shown in Table 1. Wafer or flangeless valves, bolted or through-bolt types, that are installed between flanges or against a flange are treated as flanged-end valves. Alternative rules for NPS 2½ and smaller valves are given in Mandatory Appendix V
ISO 14313:2007/Cor 1:2009	2009	API6D	Design	Petroleum and natural gas industries - Pipeline transportation systems - Pipeline valves. - 3rd edition.
ISO5211	2001		Feature	Industrial valves -- Part-turn actuator attachments
ISO5208:2008	2008	API598/9th	Test	Industrial valves -- Pressure testing of metallic valves
API598/9th	2009		Test	This standard covers inspection, examination, supplementary examinations, and pressure test requirements for resilient-seated, nonmetallic-seated (e.g. ceramic), and metal-to-metal-seated valves of the gate, globe, plug, ball, check, and butterfly types
ISO15848-1:2006	2006	API622/API624	Test	Industrial valves -- Measurement, test and qualification procedures for fugitive emissions -- Part 1: Classification system and qualification procedures for type testing of valves
ISO15848-2:2006	2006	API622/API624	Test	Industrial valves -- Measurement, test and qualification procedures for fugitive emissions -- Part 2: Production acceptance test of valves
ISO10497:2004	2004	API607/6th 2010		Testing of valves -- Fire type-testing requirements ISO 10497:2010 specifies fire type-testing requirements and a fire type-test method for confirming the pressure-containing capability of a valve under pressure during and after the fire test. It is not applicable to the testing requirements for valve actuators other than manually operated gear boxes or similar mechanisms when these form part of the normal valve assembly. Other types of valve actuators (e.g. electrical, pneumatic or hydraulic) can need special protection to operate in the environment considered in this valve test, and the fire testing of such actuators is outside the scope of ISO 10497:2010

Flow Coefficient and TORQUE*

SIZE	COEFFICIENT Cv		SIZE		275 p.s.i. 20 bar		500 p.s.i. 35 bar		720 p.s.i. 50 bar		1000 p.s.i. 70 bar		1500 p.s.i. 105 bar		2000 p.s.i. 140 bar	
	Reg. Port	Full Port	Regular Bore	Full Bore	Kgm	Ft-Lb	Kgm	Ft-Lb	Kgm	Ft-Lb	Kgm	Ft-Lb	Kgm	Ft-Lb	Kgm	Ft-Lb
1/4	-	8														
3/8	-	8	1/2	1/4 3/8	0.41	3.0	0.41	3.0	0.41	3.0	0.41	3.0	0.48	3.5	0.82	6.0
1/2	8	12	3/4	1/2	0.69	5.0	0.69	5.0	0.69	5.0	0.69	5.0	0.82	6.0	1.72	12.5
3/4	12	33	1	3/4	1.03	7.5	1.03	7.5	1.03	7.5	1.38	10.0	1.79	13.0	3.45	25.0
1	33	48	1 1/4	1	1.38	10.0	1.72	12.5	2.07	15.0	2.28	16.5	3.45	25.0	5.73	41.5
1 1/4	48	83	1 1/2	1 1/4	1.72	12.5	2.07	15.0	2.76	20.0	3.45	25.0	4.14	30.0	7.88	57.0
1 1/2	83	120	2	1 1/2	2.75	20.0	3.45	25.0	4.83	35.0	6.08	44.0	6.91	50.0	13.8	100.0
2	120	250	-	2	5.80	42.0	7.60	55.0	10.36	75.0	16.59	120.0	24.88	180.0	29.03	210.00

*Excluding TCC coating



OMB valves are manufactured in a wide range of materials, supplied by the best available steel mills, forged by well known forgery with outstanding equipment and experience. All the material can be certified in the chemical composition and the mechanical characteristic.

Material Group	Common Name	OMB code	Nominal Type	UNS	Forging Spec. (ASTM)	Casting Spec. Equivalent	DIN	DIN W.No	Application Notes
Carbon Steel	CS	A105N	C-Mn-Fe	K03504	A105N	A216-WCB	C22.8	1.0460	General non-corrosive service from -20F(-29C) to 800F(427C)
Low Temperature Carbon Steel	LTCS	LF1			A350-LF1				
	LTCS	LF2	C-Mn Si	K03011	A350-LF2	A352-LCA A352-LCB A352-LCC	TSTE 355	1.0566	General non-corrosive service from -50F(-46C) to 650F(340C), LF2 to 800F(427C).
	LTCS	LF3	3.1/2Ni	K32025	A350-LF3	A352-LC3	10Ni14	1.5637	-150F(-101C) to 650F(340C)
	LTCS	LF6	C-Mn-Si-V		A350-LF6				higher impact test value at low temp than LF2
Low Alloy Steel	Moly Steel	F1	C-1/2Mo	K12822	A182-F1	A217-WC1	15M03	1.5415	Up to 875F(468C)
	High Alloy Steel	Alloy Steel Chrome Moly	F11 cl2	1.1/4Cr-1/2Mo	K11572	A182-F11	A217-WC6	13CRMO44	1.7335
F22 cl3			2.1/4Cr-1Mo	K21590	A182-F22	A217-WC9	10CRM0910	1.7380	Up to 1100F(593C), HP steam
F5			5Cr-1/2Mo	K41545	A182-F5	A217-C5	12CRM0195	1.7362	High temp refinery service
F9			9Cr-1Mo	K90941	A182-F9	A217-C12	X 12 CrMo 9 1	1.7386	High temp erosive refinery service
F91			9Cr-1Mo-V	K90901	A182-F91	A217-C12A	X 10 CrMoV Nb 9 1	1.4903	High pressure steam
Stainless Steel	Austenitic S Steel 300 series S Steel	F304	18Cr-8Ni	S30400	A182-F304	A351-CF8	DIN X5CrNi 18 9	1.4301	0.04% min. carbon for temp.>1000F(538C)
		F304L	18Cr-8Ni (C 0.03)	S30403	A182-F304L	A351-CF3	X 2 CrNi 19 11	1.4306	Up to 800F(427C)
		F304H	18Cr-8Ni	S30409	A182-F304H	A351-CF8	n/a	n/a	
		F310	25 Cr-20 Ni		A182-F310	A351-CK20			
		F316	16Cr-12Ni-2Mo (C 0.08)	S31600	A182-F316	A351-CF8M	DIN X5CrNiMo 18 10	1.4401	0.04% min. carbon for temp.>1000F(538C)
		F316L	16Cr-12Ni-2Mo (C 0.03)	S31603	A182-F316L	A351-CF3M	X 5 CrNiMo 17 12 2	1.4404	Up to 800F(427C)
		F316H	16Cr-12Ni-2Mo	S31609	A182-F316H	A351-CF8M	n/a	n/a	
		F316Ti		S31635	A182-F316Ti		X 6 CrNiMoTi 17 12 2	1.4571	
		F321	18Cr-10Ni-Ti	S32100	A182-F321		X 6 CrNiTi 18 10	1.4541	0.04% min. carbon (grade F321H) and heat treat at 2000F(1100C) for service temps.>1000F(538C)
		F321H	18Cr-10Ni-Ti	S32109	A182-F321H		n/a	n/a	
		F347	18Cr-10Ni-Cb(Nb)	S34700	A182-F347	A351-CF8C	DIN 8566	1.4550	0.04% min. carbon (grade F347H) and heat treat at 2000F(1100C) for service temps.>1000F(538C)
F347H	18Cr-10Ni-Cb(Nb)	S34709	A182-F347H	A351-CF8C	n/a	n/a			
F317L		S31703	A182-F317L	A351-CG3M	X 2 CrNiMo 18 16 4	1.4438			
Martensitic stainless steel	F6a-13Cr - 410	F6	13Cr	S41000	A182 F6	A351-CA15			13% Cr steel (trim material)
	F6NM	F6NM		S41500	A182 F6NM	A351-CA6NM	X 3 CrNiMo 13-4	1.4313	13% Cr steel with excellent low temperature impact properties and corrosion resistance
	17-4-PH	17-4-PH		S17400	A564 UNS S17400	ASTM A494 CU5MCuC	X 5 CrNiCuNb 16-4	1.4542	
Super Austenitic Steel	Super Austenitic 6Mo	F44	20Cr-18Ni-6Mo	S31254	A182-F44	A351-CK3MCuN	X 1 CrNiMoCuN 20 18 7	1.4547	service to 600F(316C)
	Super Austenitic 6Mo	904L	44Fe-25Ni-21Cr-Mo	N08904	B649-N08904		Z2 NCDU 25-20	1.4539	
	Super Austenitic 6Mo	926		N08926			X1NiCrMoCuN 25-20-7	1.4529	virtual immunity under practical conditions to chloride-ion stress-corrosion cracking
NiCrMo S Steel	Alloy 20	ALLOY 20	28Ni-19Cr-Cu-Mo	N08020	A182-F20	A351-CN7M	DIN 1.4500	2.4660	service to 600F(316C)
	Alloy 28	ALLOY 28		N08028				1.4563	nickel based alloy (Ni/Fe/Cr) with good corrosion resistance and a high range of mechanical strength. The alloy was originally developed for use in the manufacture of phosphoric acid.
Duplex Steel	Duplex 2205	F51	22Cr-5Ni-3Mo-N	S31803 S32205	A182-F51	A890-Grade 4A (UNS J92205) - A995 CD3MN	X2CrNiMoN22 5 3	1.4462	service to 600F(316C) -The original S31803 UNS designation has been supplemented by S32205 which has higher minimum N, Cr, and Mo.
Super Duplex Steel	Super Duplex 2507	F53	25Cr-7Ni-4Mo-N	S32750	A182-F53	A351-CD4MCu A890 5A	X2CrNiMoN25 7 4	1.4410	service to 600F(316C)
	Super Duplex	F55	25Cr-7Ni-3.5Mo-N-Cu-V	S32760	A182-F55	A351 GR CD3MWCuN	X2CrNiMoCuWN25.7.4	1.4501	
	Ferrallium 255	255		S32550		ASTM A487 gr 4C	n/a	n/a	
Nickel	Nickel 200	NICKEL	99/95Ni	N02200	B564-N02200	A494-CZ-100	NW2200	1.7740	service to 600F(316C)
Nickel-Iron Alloy	Incoloy 800	ALLOY 800	33Ni-42Fe-21Cr	N08800	B564-N08800	A351-CT15C	X 10 NiCrAlTi 32 20	1.4876	
	Incoloy 800H	ALLOY 800H		N08810	B564-N08810			1.4876	
	Incoloy 800HT	ALLOY 800HT		N08811	B564-N08811			1.4876	
	Incoloy 825	ALLOY 825	42Ni-21.5Cr-3Mo-2.3Cu	N08825	B425-N08825	A494-CU5MCuC	NiCr 21 Mo	2.4858	service to 1000F(538C)
Nickel Superalloys	Inconel 600	ALLOY 600	72Ni-15Cr-8Fe	N06600	B564-N06600	A494-CY40	NiCr 15 Fe	2.4816	
	Inconel 625	ALLOY 625	60Ni-22Cr-9Mo-3.5Cb	N06625	B564-N06625*	A494-CW-6MC	DIN 17744	2.4866	*Difficult to forge in close dye
	Inconel 718	ALLOY 718	52.5Ni-19Cr-3Mo	N07718	B637-N07718			2.4668	Alloy 718 is a precipitation hardenable nickel-based alloy designed to display exceptionally high yield, tensile and creep-rupture properties at temperatures up to 1300°F (704°C).
	Hastelloy B2	ALLOY B2	65Ni-28Mo-2Fe	N10665	B564-N10665*			n/a	solid solution strengthened, nickel-molybdenum alloy, with significant resistance to reducing environments like hydrogen chloride gas, and sulfuric, acetic and phosphoric acids
	Hastelloy C-276	ALLOY C276	54Ni-15Cr-16Mo	N10276	B564-N10276*	A494-CW-2M	NiMo 16 Cr 15 W	2.4819	*Difficult to forge in close dye
Hastelloy C-22	ALLOY C-22		N06022	B462-N06022			2.4602	austenitic nickel-chromium-molybdenum-tungsten alloy with enhanced resistance to pitting, crevice corrosion and stress corrosion cracking.	
Nickel-Copper	Monel 400	MONEL	67Ni-30Cu	N04400	B564-N04400	A494-M35-1	DIN 17730	2.4365	
	Monel K500	MONEL500		N05500	B865-N05500			n/a	Available as well in 500 grade
Titanium	Titanium	TITANIUM	98Ti	R50400	B381-F2	B367-C2	Ti 2	3.7035	



	OMB DESIGNATION	CHEMICAL NAME/DESIGNATION	TEMPERATURE RANGE	APPLICATION	TRADEMARK
THERMOPLASTIC	P.T.F.E	Polytetrafluoroethylene	-100° to + 180°/220°C	Virgin PTFE is used as a standard material for its high lubricity and superior sealing up to 180°C. It is white in colour.	DuPont™ Teflon®
	R.P.T.F.E./Glass	Polytetrafluoroethylene glass filled	-100° to + 200°/250°C	Reinforced PTFE seats are made with glass filled PTFE (20%). They are harder than virgin PTFE. White in colour with green or blue speckles.	DuPont™ Teflon®
	R.P.T.F.E./Carbon Graphite	Polytetrafluoroethylene carbon-graphite filled	-100° to + 200°/250°C	Reinforced PTFE with 20% carbon and 5% Graphite. These seats are black in colour.	-
	POM (Delrin®)	Polyoxymethylene acetal resin	-57°C to 82°C	This material is very rigid it has a combination of strength, stiffness, hardness dimensional stability, toughness, fatigue resistance, abrasion resistance low wear and low friction. It can withstand pressure up to 5000 PSIG depending on valve size. Do not use on oxygen service.	DuPont™ Delrin®
	Devlon® V	Polyamide	-100° to +150°C	Devlon® V is similar to Nylon 12G, but with a wider range of temperature application (lower and higher).	Devol Eng. Ltd.
	PEEK	Polyetheretherketone	-100° to 260°C	Peek is recommended for high temperature (up to 260°C) but it is very hard compared to other non metallic materials. Not applicable for concentrated sulphuric acid.	-
	PCTFE (Kel F®)	Polychlorotrifluoroethylene	-250° + 150°C	PCTFE is specifically recommended for cryogenic service.	3-M™ KEL-F® Daikin™ Neoflon®
	Vespel® Sp21	15% Graphite Filled Polyimide	-100° to 340°C	15% Graphite filler. Performs well in a variety of chemical environments and a variety of industrial fluids at elevated temperatures.	DuPont™ Vespel®
	Nylon 12 G	Polyamide	-50° to + 120°C	Nylon 12G is more suitable than PTFE for higher pressure, but has a limited range in temperature.	-
	UHMWPE	Ultra High Molecular Weight Polyethylene	-200°C to 80°C	UHMWPE (05) is a common substitute where PTFE is not permitted and has excellent abrasion resistance.	-

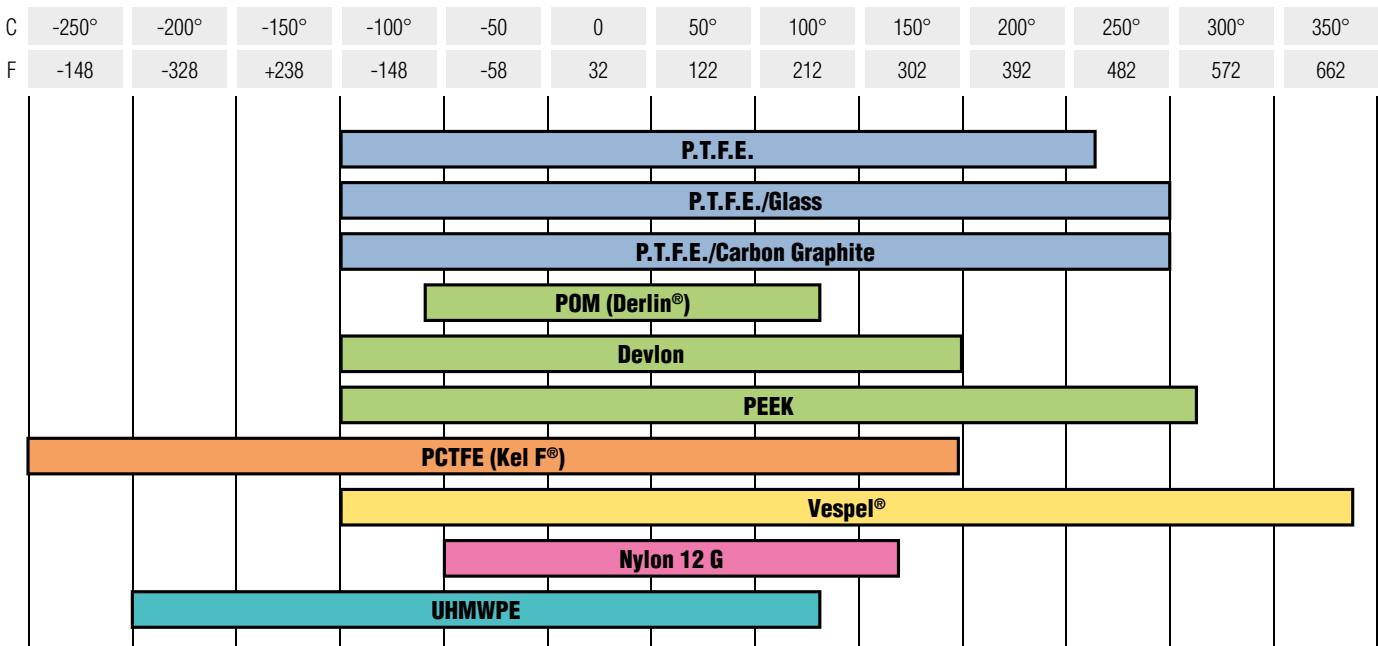

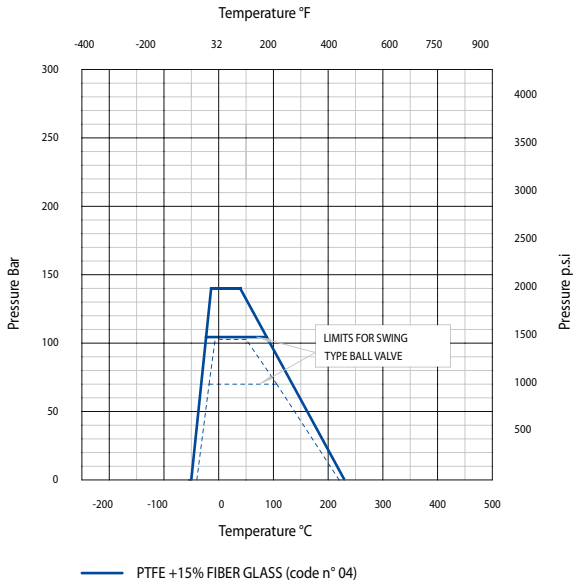

PTFE + 15% Fiberglass

The glass content decreases the characteristics when in the presence of alcohol and it can be corroded by hydrofluoric acid.

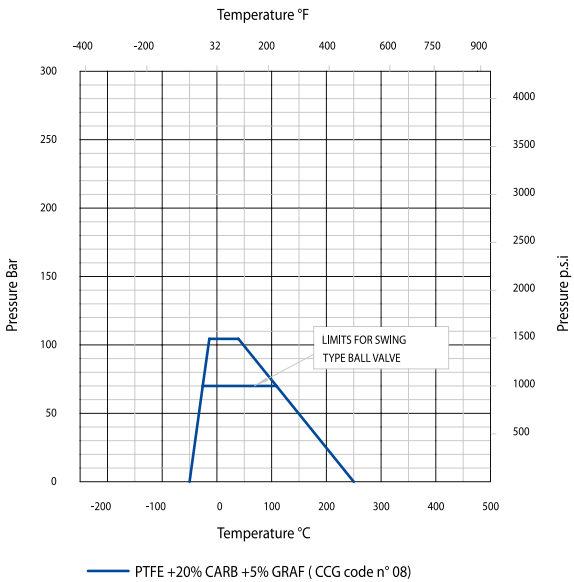

PTFE + 20% Graphite & 5% Carbon

Graphite and Carbon content increase temperature and pressure range of this compound which is the OMB standard.

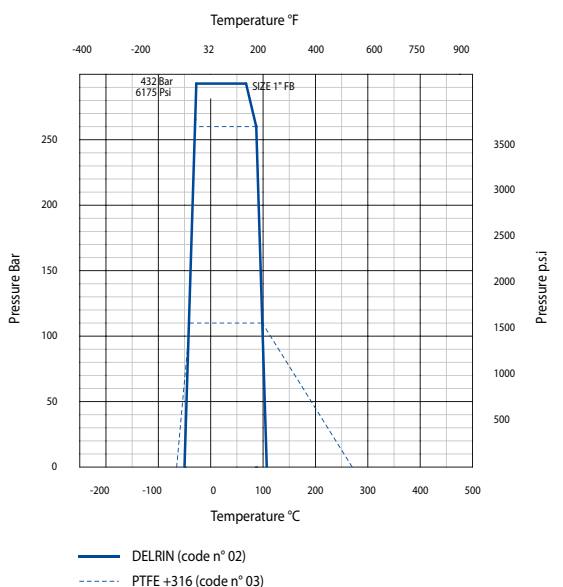

Derlin®

DuPont's trademark for Polyoxy-methylene. This material is very rigid and does not undergo cold flow. It has a combination of strength, stiffness, hardness, dimensional stability, toughness, fatigue resistance, abrasion resistance, low wear and low friction. It can withstand pressure up to 5000 PSIG depending on valve size. Has a temperature range of -70°F to 180°F (-57°C to 82°C). Better radiation rating than PTFE with maximum 1×10^6 rads lifetime dose Do not use on oxygen service. Color - glossy white.

Derlin® is a DuPont's trademark





SEAT MATERIAL PRESSURE - TEMPERATURE LIMIT

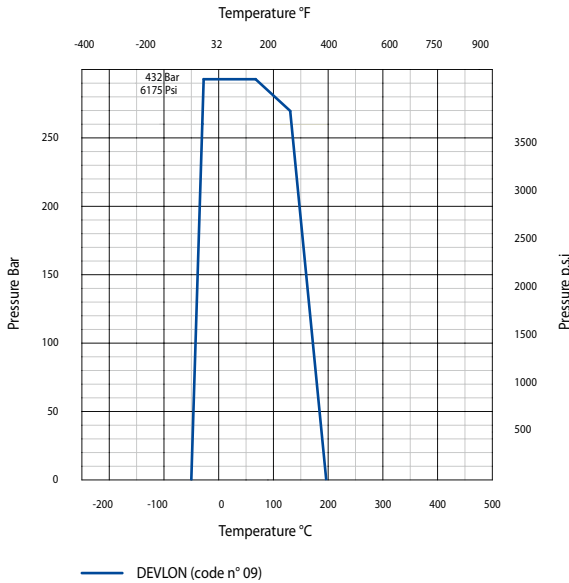

Devlon®

Devlon V-API has many advantages over nylon and PTFE, with one material replacing several thermoplastics over a wide range of operating pressures and temperatures. In comparison with virgin or glass-filled PTFE, Devlon V-API has similar friction values at low and high temperatures, with the benefit of superior dimensional stability.

It also has a considerable cost advantage over PTFE and PEEK, and can be manufactured up to 2.25m (88.6-inch) diameter.

Devlon® is a Devol Eng. Ltd trademark

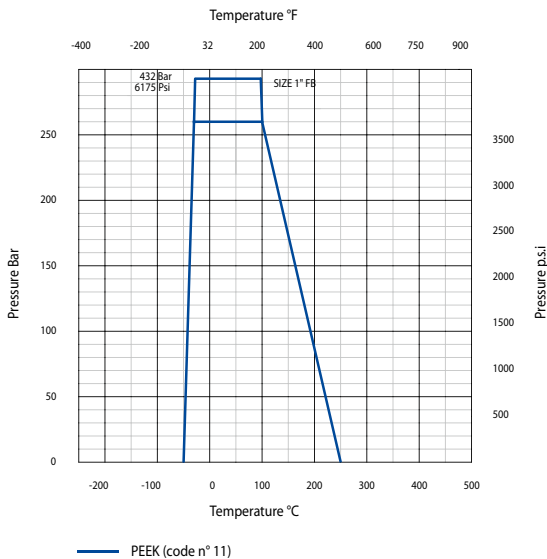

PEEK* (Unfilled) Polyetheretherketone

Peek Polymer offers a unique combination of chemical, mechanical and thermal properties. Excellent for water and steam application at elevated temperatures up to 600°F and pressures up to 6000 PSIG. Not applicable for concentrated sulfuric acid. Excellent resistance to radiation with maximum 1×10^9 rads lifetime dose. Color-beige.

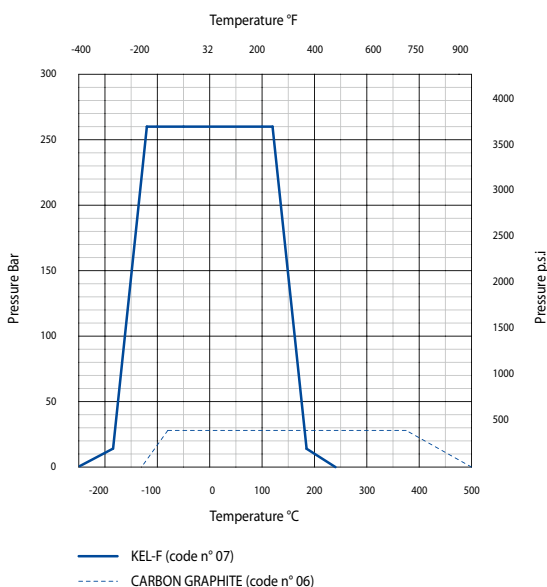

KEL-F® Polychlorotrifluoroethylene (PCTFE)

PCTFE is a fluorocarbon based polymer. It offers a unique combination of physical and mechanical properties non-flammability, chemical resistance, and near zero moisture absorption. It has a temperature range of -400°F to 400°F (-240°C to 204°C) which is suitable for **cryogenic** applications.

KEL-F® is a 3-M's trademark



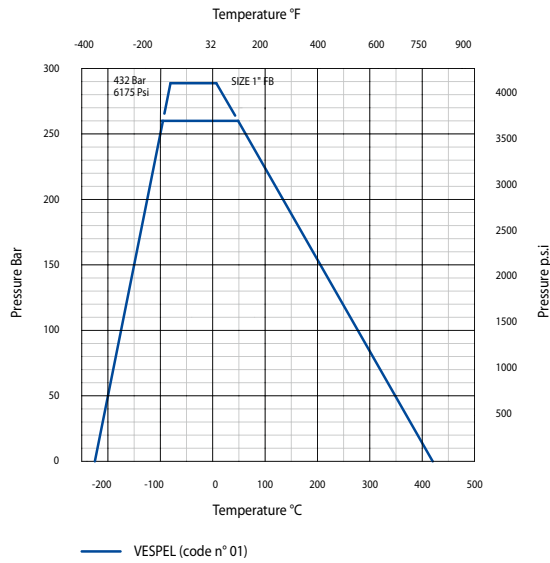

VESPEL®

VespeL® SP-1 are high-performance polyimide shapes offer a broad combination of temperature resistance, chemical resistance, mechanical toughness, natural lubricity, wear-resistance and insulation properties.

VespeL® is a DuPont's trademark

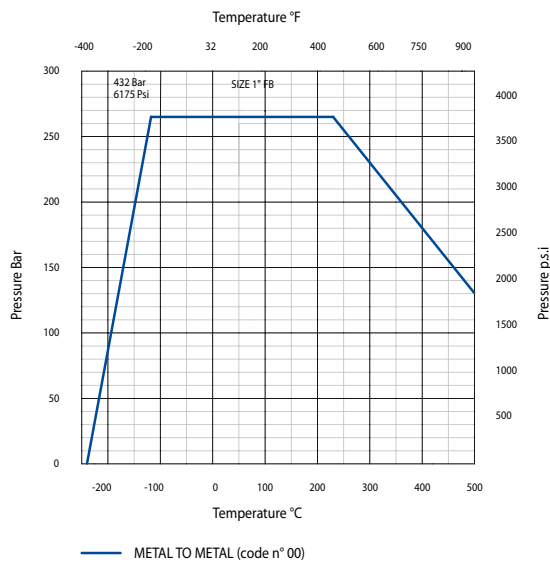

METAL TO METAL

Tungsten carbide is an inorganic chemical compound containing equal parts of tungsten and carbon. It is approximately three times stiffer than steel leading to high abrasive resistance. TCC can be used in high temperatures service where Thermoplastic cannot survive. The application method is High velocity oxy-fuel HVOF thermal spray coating done on both ball and seats. This type of finish increase the torque value of the valve and the table on page 30 is not applicable to this option.

(See table on page 37)



EXCELLENT SEALING CHARACTERISTICS

WIDE RANGE OF FLUID SERVICES

STANDARD AND EXTREME OPERATING TEMPERATURES



Superior Sealing

High precision machining results in superior ball and seat interfacing for tight shutoff conforming to ANSI B16.104 class V and MSS SP-61.

Dependable Operations

Spring loaded seats maintain close contact with the ball assuring tight sealing even at low pressures. This results in stable opening and closing torques at high differential pressures over a wide range of temperatures as well as high frequency.

Fire Safe

The combination of metal seats and soft carbon seals insure fire-safe capabilities.

Material Selection

Various material components are available for a variety of service applications up to 500° C (932° F).

Versatility

Surface-hardened ball and seats allows use in more severe applications such as slurries, pulp stock and other abrasive media in long life.

BALL/SEAT/COATING - TEMPERATURE LIMITATION GUIDELINES

BASE MATERIAL GRADES		BASE MATERIAL Temp. Limit °C	COATING	COATING Temp. Limit °C	COMBINED Temp. Limit °C
Duplex	ASTM A182 F51	370	TCC	230	230
	ASTM A182 F55		ENP	400	370
			SiC	550	370
			CCC	650	370
6Mo	ASTM A182 F44	427	TCC	230	230
	Alloy 20		ENP	400	400
			SiC	550	427
			CCC	450	427
13Cr	ASTM A 182 F6A	640	TCC	230	230
	ASTM A182 F6NM		ENP	400	400
			SiC	550	550
			CCC	450	450
CRA	625	700	TCC	230	230
	718		ENP	400	400
	X-750		SiC	550	550
	825		CCC	450	450
SS	ASTM A182 F316	700	TCC	230	230
	ASTM A182 F304		ENP	400	400
	ASTM A182 F347		SiC	550	550
			CCC	450	450

C	-200°	100°	180°	230°	250°	300°	315°	370°	380°	400°	450°	550°	650°
F	-328°	212°	356°	446°	482°	572°	599°	698°	716°	752°	842°	1022°	1202°

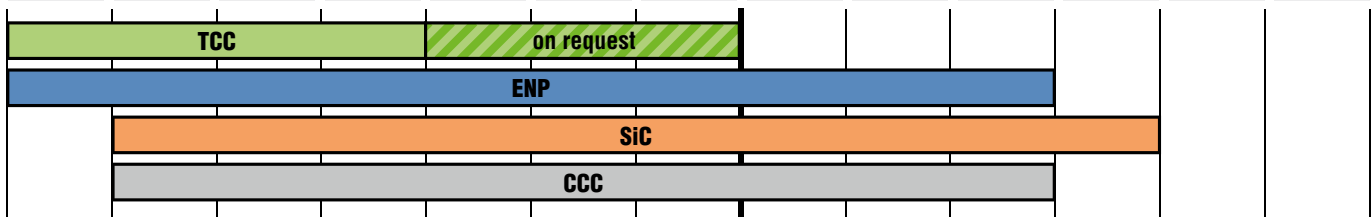

Upper limit of KAFLOW/KALREZ® | Graphite seat seal - Special design/torque

Maximum temp applicable on TCC is 230°C Recommended thickness is 150 micron
 Maximum temp applicable on CCC is 450°C Recommended thickness is 150 micron
 Maximum temp applicable on SiC is 550°C Recommended thickness is 35 micron



PRESSURE RATINGS

VALUES FROM API 6D AND API 6A

Pressure class of valve		ANSI 150 PN 20	ANSI 300 PN 50	ANSI 600 PN 100	ANSI 800 (*)	ANSI 900 PN 150	ANSI 1500 PN 250	ANSI 2500 PN 420	API 2000	API 3000	API 5000	API 10000
MAXIMUM OPERATING PRESSURE 38°C-100F	Bar	19	49.6	99.3	138	148.9	248.2	413.7	138	207	345	690
	Psig	275	720	1440	2000	2160	3600	6000	2000	3000	5000	10000
	kPa	1900	4960	9930	13800	14890	24820	41370	13800	20700	34500	69000
HYDROSTATIC SHELL TEST	Bar	29.3	75.8	150	207	224.1	372.3	620.5	276	414	690	1035
	Psig	425	1100	2175	3000	3250	5400	9000	4000	6000	10000	15000
	kPa	2930	7580	15000	20700	22410	37230	62050	27600	41400	69000	103500

1 bar = 100 kPa - 1 Psig = 0.06894757 bar - 1 bar = 14.5 Psig

(*) Class 800 is not normally tabulated ASME/ANSI B16.34 designation, but it is an intermediate class that is widely used for SW-BW and threaded and valves.

CLASS 800

According to ISO 15761

SERVICE TEMP.		A105 ⁽¹⁾ A350-LF2 ⁽²⁾	A182 ⁽³⁾ F11	A182 ⁽³⁾ F22	A182 F5	A182 F9	A182 F304	A182 F316	A182 F304L	A182 F347H
C° -29 to 38	Bar	136.2	137.9	137.9	137.9	137.9	132.4	132.4	110.3	132.4
F° -20 to 100	Psi	1975	2000	2000	2000	2000	1920	1920	1600	1920
C° 93.5	Bar	124.1	131.0	131.9	137.9	137.9	110.3	114.1	93.1	116.9
F° 200	Psi	1800	1900	1910	2000	2000	1600	1655	1350	1695
C° 149	Bar	120.7	123.8	124.5	133.8	133.8	97.2	103.1	83.4	108.3
F° 300	Psi	1750	1795	1805	1940	1940	1410	1495	1210	1570
C° 204.5	Bar	116.6	121.0	119.3	129.7	129.7	86.5	94.5	75.9	102.1
F° 400	Psi	1690	1755	1730	1880	1880	1255	1370	1100	1480
C° 260	Bar	110.0	117.9	117.6	122.4	122.4	80.3	87.9	70.3	95.2
F° 500	Psi	1595	1710	1705	1775	1775	1165	1275	1020	1380
C° 315.5	Bar	100.7	113.4	113.4	113.4	13.4	76.2	83.1	66.2	90.3
F° 600	Psi	1460	1615	1615	1615	1615	1105	1205	960	1310
C° 343.5	Bar	98.6	108.3	108.3	108.3	108.3	75.2	81.7	64.5	88.3
F° 650	Psi	1430	1570	1570	1570	1570	1090	1185	935	1280
C° 371	Bar	97.9	104.5	104.5	104.5	104.5	74.1	79.3	63.1	86.2
F° 700	Psi	700	1515	1515	1515	1515	1075	1150	915	1250
C° 399	Bar	92.7	97.9	97.9	97.9	97.9	73.1	77.9	61.7	84.8
F° 750	Psi	750	1420	1420	1420	1420	1060	1130	895	1230
C° 426.5	Bar	75.9	93.4	93.4	91.4	93.4	72.4	76.2	60.3	83.8
F° 800	Psi	1100	1355	1355	1325	1355	1050	1105	875	1215
C° 454.5	Bar	49.3	89.7	89.7	80.7	89.7	71.4	74.5	59.3	81.7
F° 850	Psi	850	1300	1300	1170	1300	1035	1080	860	1185
C° 482	Bar	715	82.8	82.8	64.8	82.8	70.7	72.4		79.3
F° 900	Psi	31.7	1200	1200	940	1200	1025	1050		1150
C° 510	Bar	460	69.3	69.3	47.9	67.9	69.0	71.0		71.0
F° 950	Psi	19	1005	1005	959	985	1000	1030		1030
C° 538	Bar	275	41.0	49.3	35.2	53.8	59.3	66.9		66.9
F° 1000	Psi	9.7	595	715	510	780	860	970		970
C° 565.5	Bar	140	25.2	36.6	25.9	34.8	56.9	66.2		66.2
F° 1050	Psi		365	530	375	505	825	960		960
C° 593.5	Bar		17.6	20.7	19.0	20.7	47.2	59.3		59.3
F° 1100	Psi		255	300	275	300	685	860		860
C° 621	Bar		9.7	19.0	12.8	13.8	35.9	50.7		50.7
F° 1150	Psi		140	275	185	200	520	735		735
C° 649	Bar		6.6	10.0	8.3	9.6	28.6	37.9		31.7
F° 1200	Psi		95	145	120	140	415	550		460

Notes: (1) Permissible, but not recommended for prolonged use above 800°.
(3) Permissible, but not recommended for prolonged use above 1050°F.

(2) Not to be used over 650°F.

CARBON STEEL A105⁽¹⁾ & A350 LF2⁽²⁾

According to ISO 15761

SERVICE TEMP.		PN20	PN50	PN100	PN250	PN420
C° 38	Bar	19.6	51.1	102.1	255.3	425.5
C° 50	Bar	19.2	50.1	100.2	250.4	417.3
C° 100	Bar	17.7	46.4	92.8	231.9	386.5
C° 150	Bar	15.8	45.2	90.5	226.1	376.9
C° 200	Bar	14.0	46.2	90.5	226.1	376.9
C° 250	Bar	12.1	41.7	83.4	208.6	347.7
C° 300	Bar	10.2	38.7	77.5	193.7	322.8
C° 350	Bar	8.4	37.0	73.9	184.8	308.0
C° 375	Bar	7.4	36.5	72.9	182.3	303.9
C° 400	Bar	6.5	34.5	69.0	172.5	287.5
C° 425	Bar	5.6	28.8	57.5	143.8	239.6
C° 450	Bar	4.7	20.0	40.1	100.2	166.9
C° 475	Bar	3.7	13.5	27.1	67.7	112.9
C° 500	Bar	2.8	8.8	17.6	44.0	73.3
C° 525	Bar	1.9	5.2	10.4	25.9	43.2
C° 540	Bar	1.3	3.3	6.5	16.3	27.2

SERVICE TEMP.		150	300	600	1500	2500
F° -20 to 100	Psi	285	740	1480	3705	6170
F° 200	Psi	260	675	1350	3375	5625
F° 300	Psi	230	655	1315	3280	5470
F° 400	Psi	200	635	1270	3170	5280
F° 500	Psi	170	600	1200	2995	4990
F° 600	Psi	140	550	1095	2735	4560
F° 650	Psi	125	535	1075	2685	4475
F° 700	Psi	110	535	1065	2665	4440
F° 750	Psi	95	505	1010	2520	375
F° 800	Psi	80	410	825	2060	3430
F° 850	Psi	65	270	535	1340	2230
F° 900	Psi	50	170	345	860	1430
F° 950	Psi	35	105	250	515	860
F° 1000	Psi	20	50	105	260	430
F° 1050	Psi	-	-	-	-	-
F° 1100	Psi	-	-	-	-	-

Notes: (1) Permissible, but not recommended for prolonged use above 800°F.
(2) Not to be used over 650°F.



CORROSION MEDIA					
	Carbon Steel	Stainless Steel 304	Stainless Steel 316	Inconel	Monel
Acetate Solvents, Crude	D	A	A	A	B
Acetate Solvents, Pure	C	A	A	A	A
Acetic Acid, 95%	D	B	A	A	A
Acetic Anhydride, Boiling	D	B	A	A	A
Acetone	B	A	A	A	A
Alcohols	B	A	A	A	A
Amines	B	A	A	A	A
Ammonia, Anhydrous	B	A	A	A	A
Ammonium Hydroxide, Hot	B	A	A	A	D
Ammonium Nitrate	B	A	A	A	C
Aniline Hydrochloride	D	D	C	B	B
Antimony Trichloride	D	D	C	B	B
Asphalt	B	A	A	A	A
Barium Chloride, 5%	C	A	A	A	A
Barium Hydroxide	C	A	A	A	A
Barium Nitrate	C	A	A	B	C
Benzene, Hot	B	A	A	A	A
Benzoic Acid	B	A	A	A	A
Blood	D	A	A	A	A
Bromine, Dry Gas	D	A	A	B	A
Bromine, Moist Gas	D	D	D	D	C
Buttermilk	D	A	A	A	A
Calcium Bisulfite, Hot	D	C	B	A	A
Calcium Chloride, Dilute	C	B	A	A	A
Calcium Hydroxide, 20%, Boiling	D	A	A	A	A
Calcium Hydrochloride, < 2%	C	C	B	B	C
Carbolic Acid, 90%	C	A	A	A	B
Carbon Dioxide, Dry	C	A	A	A	A
Carbon Disulphide	B	A	A	A	B
Chloroacetic Acid	D	D	C	B	B
Chloric Acid	D	D	C	C	C
Chlorinated Water, Sat.	D	D	C	C	C
Chlorine, Dry Gas	B	B	B	A	A
Chlorine, Moist Gas	D	D	C	D	C
Citric Acid, Dilute	D	A	A	A	A
Citric Acid, Hot, Conc.	D	C	B	B	B
Creosote, Hot	B	A	A	A	A
Cupric Chloride, 5%	D	D	C	D	D
Ethyl Chloride	A	A	A	A	A
Ethylene Glycol	A	A	A	A	A
Ferric Chloride < 1%	D	C	B	B	C
Ferric Nitrate, 5%	D	B	A	C	D
Ferric Sulfate, 5%	D	B	A	B	C
Ferrous Sulfate, 10%	C	A	A	B	A
Flourine, Dry Gas	C	C	B	A	A
Flourine, Moist Gas	D	D	D	B	A
Freon, Wet	C	C	C	B	A
Fuel Oil, 140°F	A	A	A	A	B

CORROSION MEDIA					
	Carbon Steel	Stainless Steel 304	Stainless Steel 316	Inconel	Monel
Furfural	B	B	B	B	B
Gasoline Sour	B	A	A	C	C
Gasoline Refined	A	A	A	B	A
Gelatine	D	B	A	A	A
Glucose	B	A	A	A	A
Glycerine	B	A	A	A	A
Hydrofluoric Acid, Boiling	D	D	D	D	B
Hydrofluosilicic Acid	D	D	C	B	A
Hydrogen Chloride, Dry	B	D	C	A	A
Hydrogen Chloride, Moist	D	D	D	D	C
Hydrogen Fluoride, Dry	C	D	C	A	A
Hydrogen Peroxide, Boiling	D	C	B	B	B
Hydrogen Sulfide, Dry	B	A	A	A	A
Hydrogen Sulfide, Moist	C	B	A	A	B
Iodine, Dry	D	D	B	A	A
Kerosene	A	A	A	A	A
Lactic Acid, 5%	D	B	A	A	B
Lactic Acid, 10%	D	B	A	A	B
Lactic Acid, Boiling, 5%	D	C	B	B	C
Lactic Acid, Boiling, 10%	D	D	B	B	C
Lead Acetate, Hot	D	A	A	B	B
Magnesium Chloride, Hot, 5%	D	C	B	A	A
Magnesium Hydroxide	B	A	A	A	A
Magnesium Sulfate	B	A	A	B	A
Magnesium Sulfate, Boiling	C	A	A	C	A
Mercury	B	A	A	A	B
Mercuric Chloride, < 2%	D	D	D	D	D
Mercuric Cyanide	D	B	B	B	D
Methyl Chloride, Dry	D	B	B	A	A
Milk	D	A	A	A	B
Molasses	B	A	A	A	A
Naptha	B	A	A	A	A
Nickel Chloride	D	C	B	B	B
Nickel Sulfate, Boiling	D	C	C	B	A
Nitric Acid, 20%	D	A	A	B	D
Nitric Acid, Boiling, Conc.	D	D	D	D	D
Nitrous Acid	D	B	B	B	C
Nitrobenzene	D	B	A	B	B
Oils - Miner.	B	A	A	C	B
Oxalic Acid, Boiling, 10%	C	A	A	A	A
Oxalic Acid, Boiling, 50%	D	D	C	B	B
Oxygen	B	A	A	A	A
Picric Acid	C	A	A	D	D
Potassium Bromide	D	C	B	A	A
Potassium Carbonate	B	A	A	A	A
Potassium Chlorate	B	A	A	A	B
Potassium Chloride	D	A	A	A	A
Potassium Chloride, Hot	D	C	B	B	A

CORROSION MEDIA					
	Carbon Steel	Stainless Steel 304	Stainless Steel 316	Inconel	Monel
Potassium Cyanide	B	B	B	B	B
Potassium Sulfate, Dil.	B	A	A	A	A
Propane, Liquid & Gas	B	A	A	A	A
Pyrogalllic Acid	B	A	A	B	A
Rosin, Molten	D	A	A	A	A
Salicylic Acid	D	B	B	B	B
Silver Bromide	D	B	A	C	B
Silver Chloride	D	D	D	C	B
Silver Nitrate	D	A	A	A	C
Sodium Acetate	C	A	A	A	A
Sodium Bisulfate	D	B	B	B	A
Sodium Bromide, Dil.	D	B	B	B	A
Sodium Cyanide	B	B	B	B	A
Sodium Fluoride, 5%	D	B	A	B	A
Sodium Hydroxide, 50%	B	A	A	A	A
Sodium Hyposulfite	D	B	A	B	A
Sodium Nitrate	B	B	A	A	B
Sodium Perborate	C	A	A	A	B
Sodium Peroxide	C	A	A	A	B
Sodium Phosphate, Tribasic	C	A	A	A	A
Sodium Silicate	B	A	A	A	B
Sodium Thiosulfate	D	B	A	B	B
Stannous Chloride, Sat.	D	D	B	B	B
Steam, 212°F	A	A	A	A	A
Steam, 600°F	C	A	A	A	A
Sulfite Liquors	D	C	B	D	D
Sulfur Chloride	D	C	D	B	B
Sulfur Dioxide, Moist	D	B	A	D	D
Sulfuric Acid, Conc.	B	B	B	B	D
Sulfurous Acid, Sat.	D	B	B	D	D
Tannic Acid, 10%	D	A	A	B	A
Tar, Hot	B	A	A	A	B
Tartaric Acid, 120°F	D	B	A	A	A
Toluene	A	A	A	A	A
Trichlorethylene	B	A	A	A	A
Turpentine	B	A	A	A	A
Varnish, Hot	C	A	A	A	A
Vegetable Oils	B	A	A	A	B
Vinegar	D	A	A	A	A
Water, Acid Mine	D	A	A	A	C
Water, Boiler Feed	B	A	A	A	A
Water, Distilled	D	A	A	A	A
Water, Salt Sea	D	C	B	B	A
Whiskey, Boiling	D	A	A	A	C
Wine	D	A	A	A	C
Xylene, Boiling	D	A	A	A	A
Zinc Chloride, 5%	D	C	B	B	B
Zinc Sulfate, Boiling	D	A	A	B	A

A = Substantial resistance - Preferred material of construction.
B = Moderate resistance - Satisfactory for use under most condition.
C = Questionable resistance - Use with caution.
D = Inadequate resistance - Not recommended.



Locking Device

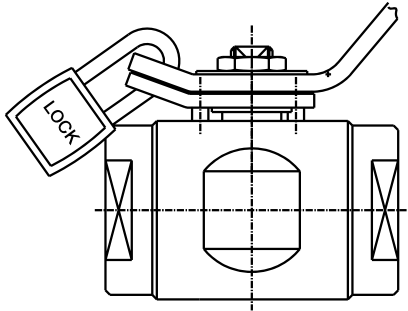

Oval Handle

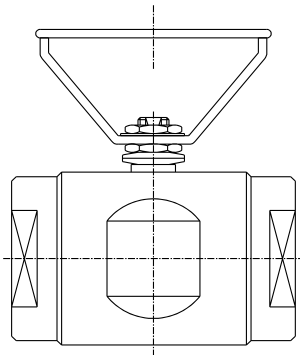

Modular Floating End Entry

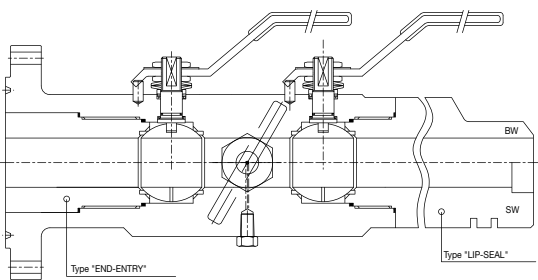

See catalog C-MV2

Modular Trunnion Side Entry

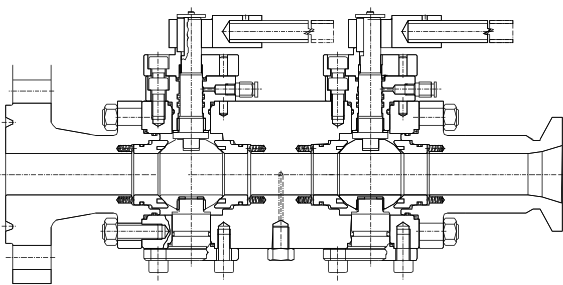

Gear Operator

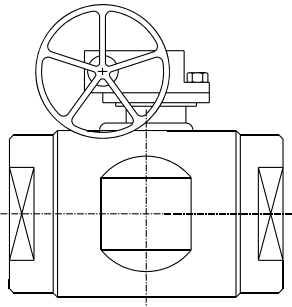

Cryogenic Service

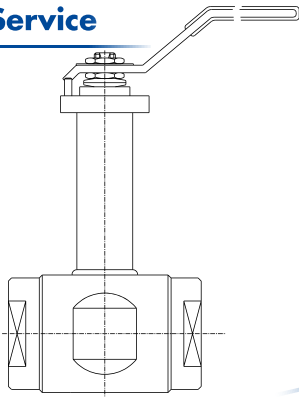

See catalog C-CR2



"T" Handle

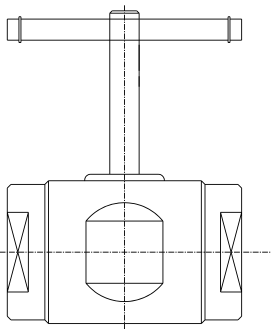

Pneumatic Operator

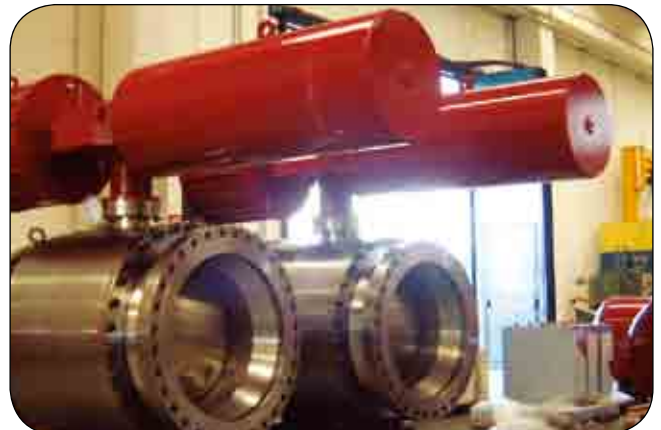
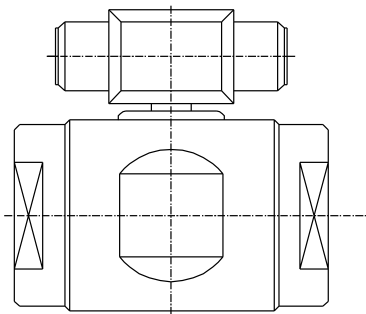

PRODUCT INFORMATION REQUEST

Request to send the following printed catalogs incopies:

From Compny

Adress..... City.....

Zip Code..... Country.....

To: OMB Valves s.p.a.
Fax: +39 035 942638

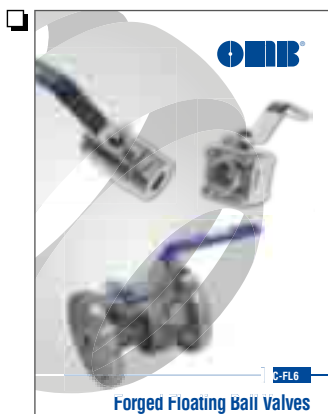
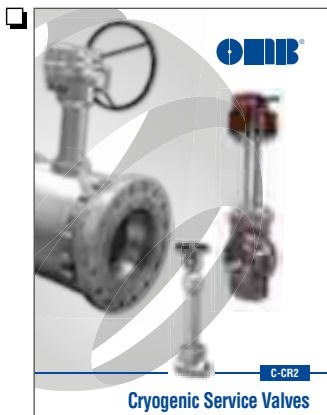

Catalogs can be downloaded at www.ombvalves.com



Worldwide Network of Agents and Distributors

OMB Offshore Application Ltd.

DUNDEE, UNITED KINGDOM
Phone +44 (0) 138 277 2992 - Fax +44 (0) 138 273 2402

OMB Valves Inc.

SUGAR LAND, TX - U.S.A.
Phone +1 832 886 2750 - Fax +1 832 886 2850

OMB Valves

Rep. office MONTREAL - CANADA
Phone +1 514 457 0813 - Fax +1 514 457 0814

OMB Valves Asia Pte. Ltd.

WOODLAND - SINGAPORE
Phone +65 685 221 10 - Fax +65 685 214 10

OMB Valves

Rep. office SOUTH EAST ASIA & PACIFIC (MALAYSIA)
Phone +60 (0) 3 806 275 96 - Fax +60 (0) 3 806 285 73

OMB Valves

Rep. office TOKYO - JAPAN
Phone +81 48 479 0960 - Fax +81 48 479 0960

OMB Valves

Rep. office SEOUL - KOREA
Phone +82 70 8244 0578 - Fax +82 2 2668 4151

OMB Valves

Rep. office BEIJING - CHINA
Phone +86 134 0113 0025 - Fax +86 10 5792 6036

IVM OMB Saudi

AL-KHOBAR - SAUDI ARABIA
Phone +966 3 889 3334 - Fax +966 3 889 3332